

**Agenda Papers**

**for**

**Project Approval Board (PAB)  
Meeting**

**on**

**26<sup>th</sup> June, 2014**

**at**

**Conference Room,  
3<sup>rd</sup> Floor, Block No. 3,  
NKN,  
DMRC Buiding,  
Shastri Park, New Delhi 110 053.**

File No.NMEICT(MS)/PAB/28

Government of India  
Ministry of Human Resource Development  
Department of Higher Education

23<sup>rd</sup> June, 2014

To,

All Members of the Project Approval Board  
of National Mission on Education through Information  
and Communication Technology.

**Sub: Agenda for 28<sup>th</sup> Meeting of the Project Approval Board (PAB) of National  
Mission on Education through Information and Communication  
Technology.**

Sir/Madam,

Enclosed please find Agenda papers for the 28<sup>th</sup> Meeting of the Project Approval Board of National Mission on Education through Information and Communication Technology **scheduled to be held on Thursday, 26<sup>th</sup> June, 2014 at 03:00 pm** under the Chairmanship of Secretary (HE), Ministry of Human Resource Development, Government of India, New-Delhi at the following venue:

**Conference Room,  
3<sup>rd</sup> Floor, Block No. 3,  
NKN  
DMRC Building,  
Shastri Park, New Delhi- 110 053**

Kindly make it convenient to attend the meeting.

Yours faithfully,

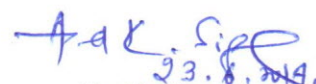

(A. K. Singh)

Director (ICT) &  
Nodal Officer (NMEICT)  
Tel: 011-23384276

Copy to:

1. PSO to Secretary (HE)
2. PS to JS (TEL)
3. PS to JS&FA
4. US (TEL)

**AGENDA FOR 28<sup>th</sup> MEETING OF PROJECT APPROVAL BOARD OF NATIONAL MISSION ON EDUCATION THROUGH INFORMATION AND COMMUNICATION TECHNOLOGY TO BE HELD ON 26<sup>th</sup> JUNE, 2014 AT 15:00 HRS AT CONFERENCE ROOM, 3<sup>rd</sup> FLOOR, BLOCK NO. 3, NKN, DMRC BUILDING, SHASTRI PARK, NEW DELHI- 110 053.**

<b>Agenda Item No.</b>	<b>Subject</b>	<b>Page No.</b>
1.	Confirmation of the “Minutes of the 27 <sup>th</sup> Meeting of the Project Approval Board held on 19 <sup>th</sup> March, 2014”.	1
2.	“Action Taken Report” on the Minutes of “27 <sup>th</sup> Meeting of the Project Approval Board” held on 19 <sup>th</sup> March, 2014.	2-5
3.	Proposal to make the BSNL Agreement of 1 Gbps Connectivity Coterminous with NKN.	6
4.	Empanelment of Government Undertakings and State IT Organizations for installing LANs at Universities.	7-8
5.	Pilot on LAN for Universities. PI: Dr. V.V.S. Murthy, DDG, NIC.	9-10
6.	LAN Funding to NKN Universities and Institutions.	11-12
7.	Creation of Common Computing Infrastructure (Release of 2 <sup>nd</sup> Installment). PI: Prof. Huzoor Saran, IIT Delhi	13-15
8.	Providing 1+1 Redundancy to all Centrally Funded Institutions in North East and J & K States.	16-17
9.	NKN/ NMEICT Direct Peering with Google. PI: Mr. R S Mani, NIC	18-19
10.	Special Permission to NIT Sikkim for 1 Gbps Connectivity.	20-23
11.	1 Gbps Connectivity to the New Private Universities.	24-26
12.	Develop an Online Joint Entrance Examination (Main) (JEE) Item Bank to Prepare Candidates for Developing the Skills that Underpin Performance on the JEE (Main) Construct. PI: Mr. Vineet Joshi, Chairman CBSE.	27-28
13.	Consulting work for preparing a Project Report for Creation of “Virtual University” in PPP model and draft “Virtual University Bill” for enactment by Parliament. PI: Mr Siddhartha Das, Executive Director, Ernst & Young LLP, Gurgaon	29-32
14.	Consulting work for Review and Amendment of applicable UGC/AICTE Regulations for incorporating Technology Enabled Learning in Higher Education. PI: Mr. Akshoy Rekhi, Abacus Legal Group, New Delhi	33-34
15.	Setting up and Providing VPN Connectivity to 200 ITIs under Director General, Employment and Training (DGET) Ministry of Labour and Employment (ML&E) Government of India.	35

<b>Agenda Item No.</b>	<b>Subject</b>	<b>Page No.</b>
16.	Office Space for Mission Secretariat NMEICT.	36-38
17.	Budget Estimate for TSG-EdCIL & Mission Secretariat of NMEICT for the Financial Year 2014-15.	39-45
18.	Any other item with the permission of Chair.	-



<b>Appendix</b>		
<b>Appendix-I</b>	: <b>Minutes</b> of the 26 <sup>th</sup> Meeting of the Project Approval Board (PAB) held on 21 <sup>st</sup> November, 2013. <i>(Agenda Item No. 1 / Page: 1).</i>	46-65
<b>Appendix-II</b>	: <b>Action Taken Report</b> on the “Minutes of “27 <sup>th</sup> Meeting of the Project Approval Board” held on 19 <sup>th</sup> March, 2014. <i>(Agenda Item No. 2 / Pages: 2 to 5).</i>	66-69
<b>Appendix-III</b>	: List of Universities connected by BSNL. <i>(Agenda Item No. 3 / Page: 6).</i>	70-97
<b>Appendix-IV</b>	: List of 127 Universities & University Level Institutions <i>(Agenda Item No. 6 / Pages: 11 to 12).</i>	98-103
<b>Appendix-V</b>	: List of Centrally Funded Institutions of Jammu & Kashmir and North Eastern States <i>(Agenda Item No. 8 / Pages: 16 to 17).</i>	104
<b>Appendix-VI</b>	: Techno-Commercial Proposal Offer of BSNL. <i>(Agenda Item No. 10 / Page: 20 to 23).</i>	105-113
<b>Appendix-VII</b>	: 38 Private Universities (pending to be connected under NKN). <i>(Agenda Item No. 11 / Page: 24-26).</i>	114-115
<b>Appendix-VIII</b>	: List of 151 New Universities Taken from UGC. <i>(Agenda Item No. 11 / Page: 24-26).</i>	116-123
<b>Appendix-IX</b>	: List of 14 Centrally Funded Institutions. <i>(Agenda Item No. 11 / Page: 24-26).</i>	124
<b>Appendix-X</b>	: Office Space for Mission Secretariat of NMEICT-JS(TEL) & Mission Director’s letter dated 19.05.2014. <i>(Agenda Item No. 16 / Page: 37).</i>	125
<b>Appendix-XI</b>	: Office Space for Mission Secretariat of NMEICT- DMRC Ltd’s letter No. DMRC/PD/L-1/ITP/780 dated 27.05.2014. <i>(Agenda Item No. 16 / Page: 37).</i>	126
<b>Appendix-XII</b>	: Office Space for Mission Secretariat of NMEICT-JS(TEL) & Mission Director’s letter No. F.No. 8-42/2013-TEL dated 04.06.2014. <i>(Agenda Item No. 16 / Page: 37).</i>	127

**Agenda Item No. - 1**

**Confirmation of the “Minutes of  
the 27<sup>th</sup> Meeting of the Project  
Approval Board” held on  
19<sup>th</sup> March, 2014.**

**Agenda Item No. 1**

The “**Minutes of the 27<sup>th</sup> Meeting of the Project Approval Board**” held on 19<sup>th</sup> March, 2014 is placed for **perusal and confirmation please (Appendix-I: Page No. 46 to 65).**

**Agenda Item No. - 2**

**“Action Taken Report” on the  
Minutes of 27<sup>th</sup> Meeting of the  
Project Approval Board held on  
19<sup>th</sup> March, 2014.**

## Agenda Item No. 2

The “**Action Taken Report**” on the Minutes of the “27<sup>th</sup> Meeting of the Project Approval Board” held on 19<sup>th</sup> March, 2014, is placed at **Appendix-II (Page No. 66 to 69 )** and also reproduced below:

### Action Taken Report of the last PAB Meeting

Item	Action Taken
<p><b>Item No.3</b></p> <p><b>Approval of New Proposals:</b></p> <p><b>Proposal : Integrated E-Content Portal</b> <i>Institute: INFLIBNET</i></p> <p><b>PAB approved the project initially for One Year (Rs. 106.76 Lakhs for 2014-15)</b> with following observations:</p> <ul style="list-style-type: none"><li>a) As per the decision of the SC meeting held on 3<sup>rd</sup> March 2014, a Policy document on e-Content creation, management and access is to be prepared by Mr. Pradeep Varma, Senior Consultant (NMEICT) on issues of mapping of this integrated E-Content Portal with other NMEICT e-Content sites. This document will also include issues relating to licensing and access. The Document is to be submitted by him to next SC meeting.</li><li>b) The Content to be delivered through upcoming DTH Channels will also be included in this Portal.</li><li>c) After this proposal gets implemented, separate proposals can be taken up for creation of communities for different disciplines.</li><li>d) Mr. Ajit Balakrishnan, PAB member offered to get associated with the project for enhancing and promoting usage of the Portal with effective deployment of SEO and related techniques. PI may invite him to chair the PRSG meetings for the Project.</li><li>e) Version numbering of all Contents uploaded on Portal needs to be done.</li><li>f) Provision for rating of various e-Content to be provided.</li></ul>	<p><b>1<sup>st</sup> installment of Rs. 32.00 lakhs has been released to INFLIBNET, Ahmedabad.</b></p>

Item	Action Taken
<p><b>Item No.4, 5 &amp; 6</b></p> <p><b>Proposal(s): Utilization of NMEICT Products in State Technical Universities in the Southern, Western and Northern Regions.</b></p> <p><i>Nodal Institute: NITTTR Chennai, Bhopal and Chandigarh.</i></p> <p>After extensive discussions, <b>PAB approved the project “in principle”</b> with following observations:</p> <ol style="list-style-type: none"> <li>a) NITTTR should separately work out the cost details in two parts. First part would be the funds needed by NITTTR for Coordination and Monitoring as an extended arm of NMEICT for roll out and implementation of major NMEICT products in colleges and the second part would be for direct NITTTR budget component of training at various levels.</li> <li>b) The proposals should also carefully detail the roles of NMEICT Coordinators at various levels.</li> <li>c) The re-worked cost proposals will be presented to SC for detailed examination and recommending the exact amount to proceed further. The resolution by Chairman SC specifying the exact amount recommended will be put up in file for Chairman PAB’s approval.</li> <li>d) There is no need for coming back to PAB for these Items again.</li> </ol>	<p><b>Standing Committee has authorized standing committee Chairman to take decision in this regard.</b></p>
<p><b>Item No.7</b></p> <p><b>Subject :Open Licensing Policy Guidelines</b></p> <p>After discussions, PAB approved the Policy guidelines as proposed.</p>	<p><b>Workshop with stakeholders was conducted to popularize the decision.</b></p>
<p><b>Item No. 8</b></p> <p><b>Project: Academic Incentives for Faculties involved in Blended Learning/ Technology-Enabled Learning Initiatives of NMEICT.</b></p> <p>As a matter of policy, the concept of Academic Incentives for adopting and using TEL initiatives was <b>recommended in principle by PAB</b>. However the members decided that this matter should be forwarded to UGC for their detailed examination and reverting back. The members desired that <b>“Action Taken Report” from UGC should be put up in the next PAB meeting.</b></p>	<p><b>Will follow up with UGC</b></p>

Item	Action Taken
<p><b>Item No: 9</b></p> <p><b>Proposal: Virtual Labs (Phase II):</b> Institute: IIT Delhi</p> <p><b>PAB approved the project for funding of Rs. 6899.16 Lakhs</b> as proposed by PI with following observations:</p> <ul style="list-style-type: none"> <li>a) PI was advised to co-opt C-DAC as a co-PI Institution to help with the technical work of integration.</li> <li>b) For all Simulation Lab experiments constituting about 80% of total developed Labs, faster dissemination may be ensured by PI by putting them on DVDs and distribution to the Institutions.</li> <li>c) PRSG has to be re-constituted for Phase II of the Project.</li> </ul>	<p><b>1<sup>st</sup> installment of Rs. 14.15 Cr. for Virtual Lab Ph II has been released to IIT Delhi.</b></p>
<p><b>Item No. : 10</b></p> <p><b>Project: ICT Mapping in Higher Education between IIT Bombay and the National University of Singapore.</b></p> <p><b>Institute: IIT Bombay</b></p> <p><b>PAB approved the Proposal.</b></p>	<p><b>1<sup>st</sup> installment of Rs. 15.93 lakhs has been released to IIT Bombay.</b></p>
<p><b>Item No. 11</b></p> <p><b>Proposal: FOSSEE: Adoption of Free and Open Source Software in Education (Phase II).</b></p> <p><b>Institute: IIT Bombay</b></p> <ol style="list-style-type: none"> <li>1. <b>The project was approved in principle for funding of Rs. 15.99 Crores</b> as proposed by PI.</li> <li>2. PAB asked the PI to provide details of usage of its various sub-components as well as set targets for outreach activities to be undertaken in the project. These details are to be presented at the next Standing Committee meeting by the PI.</li> </ol>	<p><b>1<sup>st</sup> installment of Rs. 4.45 Cr. has been released to IIT Bombay.</b></p>

Item	Action Taken
<p><b>Item No. 12</b></p> <p><b>Proposal:</b> Creation of Courseware e-content Development for remaining 58 UG Subjects at an enhanced rate of Rs.34,000 per Module.</p> <p><b>Institute:</b> CEC &amp; EMMRCs</p> <p>The proposal is based on the request made by the Director CEC, the recommendations of the SC in its meeting held on 6th December 2013 and the due diligence conducted by the KPMG, for development of e-content by CEC for left over 58 UG subjects (out of 87 Subjects allotted) with revised cost of Rs.34,000 per Module.</p> <p>After discussions, <b>PAB agreed for the unit cost of Rs. 31,000 per Module</b> (Rs 29,000/- + Rs 2,000 as the transcription charges).</p>	<p><b>Rs. 17.80 crore has been released to CEC</b></p>
<p><b>Item No. : 13</b></p> <p><b>Proposal :</b> Creating Accessible Study Material for Print Impaired Student (Main Phase).</p> <p><b>Institute :</b> Indian Institute of Technology, Kharagpur.</p> <p>The Proposal was deferred for discussion.</p>	
<p><b>Item No. 14</b></p> <p><b>Project :</b> Creation of an Expert Database (VIDWAN)</p> <p><b>Institute:</b> INFLIBNET Centre, Gandhinagar.</p> <p><b>PAB approved the project as proposed.</b></p>	<p><b>1<sup>st</sup> installment of Rs. 15.81 lakhs has been released to INFLIBNET, Ahmedabad.</b></p>
<p><b>Item No.15</b></p> <p><b>Other item discussed with the permission of Chair:</b></p> <p>An E-mail should be sent by UGC and AICTE for their constituent Universities and Engineering Colleges for using the connectivity provided by NMEICT to the full extent. In that mail, a short note on NMEICT available projects may be attached. Mission Director (NMEICT) to take up with UGC and AICTE.</p>	<p>NMEICT brochure has been shared with Chairman AICTE and Chairman UGC for further transmission to the Colleges and Universities.</p>



**Agenda Item No. - 3**

**Proposal to make the BSNL  
Agreement of 1 Gbps  
Connectivity Coterminous with  
NKN.**

## **Agenda Item No. 3**

### **Proposal to make the BSNL Agreement of 1 Gbps Connectivity Coterminous with NKN.**

#### **3.1 Background**

National Mission on Education through Information and Communication Technology (NMEICT) was approved by the Cabinet Committee on Economic Affairs (CCEA) on the 2<sup>nd</sup> January, 2009. In the Mission Connectivity to 419 Universities/ University Level Institutions in the Country on rental basis permitting their Seamless Integration in the Integrated National Knowledge Network (NKN) are being provided. The connectivity being provided is for 10 years from the date of provisioning.

In March, 2010, the Cabinet Committee on Infrastructure (CCI) approved establishment of National Knowledge Network (NKN). Under NKN, 400 Universities and 1100 Scientific and Other Institutions are supposed to be connected. The time frame of NKN is 10 years from the date of approval of the Scheme and Connectivity is provided up to December 2019.

#### **3.2 Proposal**

In view of the mandate of CCEA for Seamless Integration with NKN, the Universities connected under NMEICT are being migrated to the NKN. Presently 338 Universities have been migrated and they are now part of NKN. Since, presently, the Time Frame of NKN is 10 years (up to December 2019), it is felt that the connectivity provided to the Universities/ University Level Institutions under NMEICT should also be coterminous with the NKN. List Universities Connected by BSNL with their date of commissioning is given in **Annexure-III / Pages: 70 to 97**. With making it coterminous with NKN there will be a saving of approximately Rs. 27 crores which will be adjusted from the future bills of BSNL. M/S BSNL will be asked to return the proportionate contribution to the concerned Universities.

**The proposal was discussed in the meeting of the Implementation-cum-Monitoring Committee of NMEICT on dated 16.06.2014; the Committee has recommended the proposal.**

**The above proposal to make the BSNL Agreement of 1 Gbps Connectivity Coterminous with NKN is placed before the PAB of NMEICT for consideration and its approval.**

**Agenda Item No. - 4**

**Empanelment of Government  
Undertakings and State IT  
Organizations for Installing  
LANs at Universities.**

#### **Agenda Item No: 4**

#### **Empanelment of Government Undertakings and State IT Organizations for installing LANs at Universities.**

Apart from providing VPN over Broad Band Connectivity to Colleges (maximum of 20 Connections of 512 Kbps each), BSNL was also asked to implement a Local Area Network (maximum 400 nodes) to each University. Under this scheme, each University was to bear 25% of the cost of the LAN and NMEICT would bear 75% of the cost (10% and 90% respectively in the case of J&K and North East).

BSNL floated a tender for this purpose and Standardized on the following cost schema per University:

<b>Item</b>	<b>Cost</b>
For up to 400 nodes LAN setup	Rs. 40 Lakhs maximum.
Charges for AMC for equipment for 2 years (2 years under warranty and 2 years paid, Total 4 years cover till end of current Mission period i.e. 2017).	Payable @ 5% of installed equipment cost for years 3-4.
Provision of one on-site Engineer	Rs. 20,000 per month for 4 years till end of current Mission Period.
Supervision Charges.	Payable @ 15%

We have been informed by BSNL that they had awarded the work to a vendor but later had to cancel the order due to non-performance. BSNL has informed that they have now re-tendered and new order is in process. Till now BSNL has implemented LAN in 50 Universities only.

Now therefore, in order to speed up the process of providing LANs to Universities, it is proposed to empanel additional agencies for the job. Proposed agencies are

- 1) ERNET
- 2) NIC
- 3) State IT Organizations (e.g. Chips Chattisgarh, BELTRON etc)

It is proposed that each of the above agencies will be asked to work within the cost cap given above. Those State IT organizations that come forward would take responsibility for the Universities in their own states. ERNET and NIC would be responsible for the balance Universities. The joint proposal for the concerned university and the implementing agency will be scrutinized and approved by the connectivity committee before the release of fund to the Implementing Agency. The fund will be released to the implementing agency as per guidelines of Mission Document.

**The proposal was discussed in the Meeting of the Implementation-cum-Monitoring Committee of NMEICT on dated 16.06.2014; the Committee has recommended the proposal.**

**The above proposal of Empanelment of Government undertakings and State IT Organizations for installing LANs at Universities is placed before the PAB of NMEICT for consideration and its approval.**

**Agenda Item No. - 5**

**Pilot on LAN for Universities.**

**Agenda Item No: 5****Proposal : Pilot on LAN for Universities****PI : Dr. V.V.S. Murthy, DDG (NIC)****Implementing Agency : NIC****Background and Requirement of the Project**

From providing VPN over Broad Band Connectivity to Colleges (maximum of 20 Connections of 512 Kbps each), BSNL was also asked to implement a Local Area Network (maximum 400 nodes) to each University. Under this scheme, each University was to bear 25% of the cost of the LAN and NMEICT would bear 75% of the cost (10% and 90% respectively in the case of J&K and North East).

BSNL floated a tender for this purpose and standardized on the following Cost Schema per University:

<b>Item</b>	<b>Cost</b>
For up to 400 nodes LAN setup	Rs. 40 Lakhs maximum
Charges for AMC for equipment for 2 years (2 years under warranty and 2 years paid, Total 4 years cover till end of current Mission period i.e. 2017)	Payable @ 5% of installed equipment cost for years 3-4.
Provision of one on-site engineer	Rs. 20,000 per month for 4 years till end of current Mission Period.
Supervision Charges	Payable @ 15%

We have been informed by BSNL that they had awarded the work to a vendor but later had to cancel the order due to non-performance. BSNL has informed that they have now re-tendered and new order is in process. Till now BSNL has implemented LAN in 50 Universities only

Apart from above, at its meeting on January 24<sup>th</sup> 2014, the Network and Implementation Committee of NMEICT recommended as follows **“Detailed Technical discussions were held amongst Committee members on this issue. After deliberating, members recommended that the Design of the Network should be amended such that all colleges would be connected to their affiliating Universities and the University would connect to the NKN network.**

**The advantage of such a network would be that University would take responsibility for all traffic to and from their affiliating Colleges and NMEICT/NKN would only manage the Network up to the University.”**

Since this redesign involves merging two disparate networks, it is proposed that the exercise be done as a Pilot. It is now, therefore, proposed to have a pilot implementation done at 7 Universities across India where NIC will be asked to set up a LAN (same terms as BSNL). More importantly, NIC will also be asked to study the existing network architecture and redesign it such that the recommendation of the Committee quoted above can be actualized.

The 7 Universities that have been initially selected for this Pilot are:

- 1) Rajiv Gandhi University, Rono Hills, Doimukh, Itanagar, Arunachal Pradesh, India - 791 112.
- 2) Kuvempu University, Jnana Sahyadri, Shankaraghatta Shimoga Dist., Karnataka, India - 577451.
- 3) Bhupendra Narayan Mandal University, Laloo Nagar, Madhepura - 852113.
- 4) Mahatma Gandhi Kashi Vidyapeeth, Varanasi, UP - 221002.
- 5) Barkatullah University, Habib Ganj, Bhopal, Madhya Pradesh- 462026.
- 6) Martin Luther University, Dongkatieh, Block - 1, Nongrah, Shillong 793006, Meghalaya.
- 7) BharatiVidyapeeth, Pune, Maharashtra 411030.

A MoU is in the process of being signed between NMEICT, NIC, NICS and the University concerned. As of now, Barkatullah University and Martin Luther University have already signed the MoU. The MoU with Mahatma Gandhi Kashi Vidyapeeth and Rajiv Gandhi University, Itanagar are in the process of being signed.

**The proposal was discussed in the meeting of the Implementation-cum-Monitoring Committee of NMEICT on dated 16.06.2014; the committee has recommended the proposal.**

**The above proposal of Pilot on LAN for Universities is placed before the PAB of NMEICT for consideration and its approval and release of Rs. 2.52 Crore to M/s NIC.**



**Agenda Item No. - 6**

**LAN Funding to NKN  
Universities and Institutions.**

## **Agenda Item No. 6**

### **Proposal: LAN Funding to NKN Universities and Institutions.**

#### **6.1 Background**

Under NMEICT, 1Gbps Optical Fiber (OFC) Connectivity, to 419 Universities/Deemed Universities and Institutions of National Importance are being provided. LAN of up to 400 nodes on average has also been envisaged to be provided to the Universities under the NMEICT scheme. The work of Connectivity and LAN has been entrusted to BSNL-MTNL combine. The funding pattern is 75:25 i.e. 75% from central and 25% from the State/ Universities/ Institutions concerned. In case of NER States this ratio is 90:10.

Under National Knowledge Network (NKN) Scheme, 400 Universities and 1100 Scientific and Other Institutions are to be connected on OFC. The funding pattern in case of NKN is 100:0. Under NKN, no provision of providing LAN to the Universities/ Institutions is there.

#### **6.2 Proposal**

As per the information available, Connectivity to nearly 835 Universities/ Institutions/ Organizations/ Laboratories under various categories throughout the country has been provided under NKN. There are about 127 Universities/ University Level Institutions and 237 Engineering & Medical in the list where the Connectivity has been provided under NKN. As without LAN entire benefit of 1 Gbps Connectivity cannot be derived, hence LAN of up to 400 nodes in 127 universities/ university level institutions connected under NKN may be considered. The list of these 127 Universities/ University Level Institutions is available at **Appendix-IV/ Pages: 98 to 103.**

### 6.3 Financial Implications

The Project Approval Board (PAB) of NMEICT in its 9<sup>th</sup> meeting held on 3<sup>rd</sup> September 2009 has approved the charges of the LAN of up to 400 nodes by the BSNL. These are as indicated in the table below:

**Table:**

S.No.	Component	Quantity	Unit rate	Total
1.	Router	1	Rs. 400,000	Rs. 400,000
2.	Gigabit Ethernet Switch (24 port)	1	Rs. 1,00,000	Rs. 1,00,000
3.	Ethernet Switch 24 Port	20	Rs. 30,000	Rs. 600,000
4.	OF Cable Laying	7.5 Km.	Rs. 2,00,000	Rs. 15,00,000
5.	CAT-5 Cable including ducting	10,000	Rs. 100	Rs. 10,00,000
6.	LAN points	400	Rs. 1,000	Rs. 400,000
	<b>Total</b>			<b>Rs. 40,00,000</b>

In addition following charges were also approved:

- a) Facility Management Charges (FMS): Actual +15% subject to a minimum of 10% of LAN Capex. This amount was estimated at Rs. 4 Lakhs/ University.
- b) Annual Maintenance Charges (AMC) for 5 years: Actual +15% subject to a minimum of 10% of LAN Capex.

Considering cost sharing ratio of 75:25, as approved in case of NMEICT, the approximate estimated cost for setting up of LAN of up to 400 nodes in 127 Universities will be nearly Rs. 38.1 crores { 127 Universities\* Rs. 40 lakhs\* 0.75}.

**The proposal was discussed in the meeting of the Implementation-cum-Monitoring Committee of NMEICT on dated 16.06.2014; the Committee has recommended the proposal.**

**The above proposal of providing LAN funding of Rs. 38.1 Crores to 127 Universities and Institutions connected under NKN is placed before the PAB of NMEICT for consideration and its approval.**



**Agenda Item No. - 7**

**Creation of Common  
Computing Infrastructure**

**[Release of 2<sup>nd</sup> Instalment]**

**PI: Prof. Huzoor Saran.**

## **Agenda Item No. 7**

**Proposal** : **Creation of Common Computing Infrastructure (Release of 2<sup>nd</sup> Installment).**

**PI** : **Prof. Huzoor Saran**

**Institute** : **IIT Delhi**

### **7.1 Background**

- i) The project was sanctioned by the PAB in March 2012 for setting up Common (Cloud) Computing Infrastructure at the NIC Data Centre in Delhi for NMEICT Projects. Total Sanction amount 40cr. Funds Released 12 cr (30%).
- ii) IIT Delhi has designed and implemented Baadal Cloud Computing Software so that such a common infrastructure can be used to offer multiple independent compute instances in a scalable manner based on individual project needs.
- iii) A pilot deployment at IIT Delhi with 200 Compute Cores and 20TB of storage was set up and has been tested over past 6 months. Due to bandwidth constraints this is not accessible outside IIT Delhi currently.
- iv) The pilot deployment has been made available to Virtual labs and some other local NMEICT projects in the testing phase.
- v) A pilot deployment at NIC data centre with 600 Computer cores is in an advanced stage of setup. This is expected to be functional in next two weeks.
- vi) This deployment being in NIC data centre would be able to have good bandwidth access through NKN and hence will be able to host projects such as NPTEL and provide excellent bandwidth and compute.
- vii) Equipment has also been ordered and has arrived for a larger 2000 core deployment. However since NIC data centre does not have adequate space to house the larger deployment, a suitable location is being examined by NIC.

- viii) NIC has worked out a proposal to hire space from BSNL data centre in Ghaziabad. In a communication received from NIC it has been mentioned that BSNL data center at Ghaziabad is being looked at for the feasibility of extending the existing NDC to get more rack space for the projects has been visited. The complete IT INFRA will be from NIC, only the rack space, AC and UPS will be from the BSNL. Similar facility Railtel is also creating in Gurgaon but that would take at least 3 months to start. The process to extend the NDC will take at least 2 months with BSNL so process should be initiated.
- ix) Financial implications: As NIC has to pay to BSNL @11 lacs per rack per year and that would approximately cost Rs. 6.6 crores for three years for 20 racks, a letter giving the assurance that MHRD would pay the above mentioned amount (tentative) when ever NIC gets in agreement with BSNL or any others like Railtel etc., was requested by the NIC. This way when the agreement materializes NIC would shift the MHRD services to the new location and pay also for the rack space hired for MHRD services. For enabling them to do initial discussion, in principal approval has been given by the Ministry.
- x) As the second Installment of the project “Creation of Common Computing Infrastructure” is due to IIT Delhi, Prof. Huzur Saran, PI of the project may be asked to pay the Rack Space Charges of Rs. 6.6 Crores for three years to NIC from the second installment of the project.
- xi) For the larger deployment, since it will no longer be on the NIC site, additional funds will be needed for storage, additional networking and firewall, load balancing equipment and manpower. This is estimated to cost approximately Rs. 7.5 crores. It is therefore requested that the second installment of 30% of project sanction i.e. Rs. 12 Crores be released so that the full deployment can take place in the next 4 months.

- xii) Funds will also be required for laying a 10GBPS Network link between NIC/NKN Data centre at Shastri-Park and the BSNL data Centre. Based on NIC empanelled rates the cost of the link is estimated at Rs. 1.25 Cr per annum. Permission is sought for direct payment of the above account to NIC from the Connectivity budget of the mission to enable an early setup of this link along with the data centre space procurement.

**The proposal was discussed in the Meeting of the Implementation-cum-Monitoring Committee of NMEICT on dated 16.06.2014; the Committee has recommended the release of Second Installment of Rs. 12.0 crores for the project. The committee has also recommended that “Rack Space Charges” of Rs. 6.6 crores for three years to NIC should also be paid from the second installment due to the project. Prof. Huzoor Saran, IIT Delhi and PI of the Project has also agreed for the same.**

**The following are put before PAB for consideration and approval :**

- a) Release of Second Instalment of Rs. 12.00 Crores of the Project “Creation of Common Computing Infrastructure”.**
- b) Permit BSNL to provide 10 Gbps Connectivity between NMEICT Data Centre and NKN central node from the fund released for providing Connectivity to Universities till Dec, 2019.**

**Agenda Item No. - 8**

**Providing 1+1 Redundancy to  
all Centrally Funded  
Institutions in North East and  
J & K States.**



## **Agenda Item No. 8**

### **Providing 1+1 Redundancy to all Centrally Funded Institutions in North East and J & K States.**

#### **8.1 Background**

The reliable (uptime, speed) connectivity is central to the Technology Enabled Learning. NMEICT is getting constant feedback from the user university, particularly from Jammu & Kashmir and North East, regarding its dissatisfaction about reliability of connectivity. This issue was deliberated extensively by the expert group of NMEICT on connectivity. The group was of the view that providing 1+1 redundant path is the only solution. The issue of connectivity has also been discussed in the conference of the Vice Chancellors of the Central Universities and of the Directors of the National Institute of Technology last year at Rastrapati Bhawan, New Delhi. One the recommendation emerged from the conference was to provide alternate, back-up links (from BSNL/ RailTEL/ Powergrid) and Telecom PSUs should ensure continuous availability of bandwidth.

#### **8.2 Proposal**

Accordingly it has been thought of to provide 1+1 connectivity to the Centrally Funded Institutions of Jammu & Kashmir and North Eastern States to which the connectivity has been provided under NMEICT scheme till December 2019 i.e. the period of the Connectivity provided under NKN scheme. A list of such Institutions is available at **Annexure-V/ Pages: 104**. There are 23 Universities/ University Level Centrally Funded Institutions in these States (3 in J&K and 20 in North Eastern States). As the NIC, under NKN scheme has already provided the Connectivity to the Institutions and the Universities through RailTEL/ Powergrid and is having a MoU with them. The NIC may be requested to take up the responsibility of providing the redundant connectivity on NKN Style to the Centrally Funded Institutions of MHRD of the Jammu & Kashmir and North Eastern states on payment basis.

### **8.3 Financial Implications**

Rate as approved by NKN for 1 Gbps OFC Connectivity for 10 years = Rs. 2 crores. Considering only 5 years left for period up to December 2019, the charge for 5 years will be Rs. 60 lakhs { 2 crores/ 10\*3 = 0.6 crores } per University/ University Level Institutions. For 23 Universities/ University Level Institutions the charges for 5 years will be Rs. 13.8 Crores {23\* Rs 0.60= Rs.13.8 crores}.

**The proposal was discussed in the Meeting of the Implementation-cum-Monitoring Committee of NMEICT on dated 16.06.2014; the Committee has recommended the proposal.**

**The above proposal of providing 1+1 redundancy to all Centrally Funded Institutions in North East and J & K States at a cost of Rs. 13.8 Crores with NIC as Implementing Agency is placed before the PAB of NMEICT for consideration and its approval.**

**Agenda Item No. - 9**

**NKN/ NMEICT Direct  
Peering with Google.**

## **Agenda Item No: 9**

**Project** : **NKN/NMEICT Direct Peering with Google**  
**PI** : **Mr. R. S. Mani**  
**Implementing Agency** : **NIC**

### **Background and Requirement of the Project**

Based on various statistics that have been collected over a period of time and also based on the feedback of researchers from various institutes, NKN /NMEICT noticed that the users have been using various resources from Google extensively. The traffic from Google was about 7-8 Gbps and majority of the same is for YouTube which has a plethora of knowledge contents including an NPTEL YouTube channel.

In order to reduce the cost involved in hiring Internet bandwidth for catering to the needs of users and also to provide better user experience through speed and quality, Google Global Cache (GGC) has been implemented for use in NKN / NMEICT. GGC represents the final tier of Google's content delivery platform, and is closest to users. With GGC, network operators and Internet Service Providers deploy a small number of Google servers inside their network to serve popular Google content such as YouTube. Google's traffic management system directs users to the node that will provide the best performance for the user.

This concept is referred as direct peering and in this case it is with Google Data Centers. It is proposed to connect to Google Data Centers at Delhi & Chennai with 2x10Gbps links. NKN has three primary connectivity providers namely BSNL/Raitel/PGCIL/MTNL for which rates have already been established.

It is proposed to hire bandwidth from the above mentioned CPSU long distance leased circuit providers and connect to Google data Centre Directly. It is also expected that the traffic flowing through these links would grow over a period of time.

### **Justification of cost**

Google has Data Centers at New Delhi and Chennai. Under the proposed scheme, these would be connected by NKN PoPs at New Delhi and Chennai to start with.

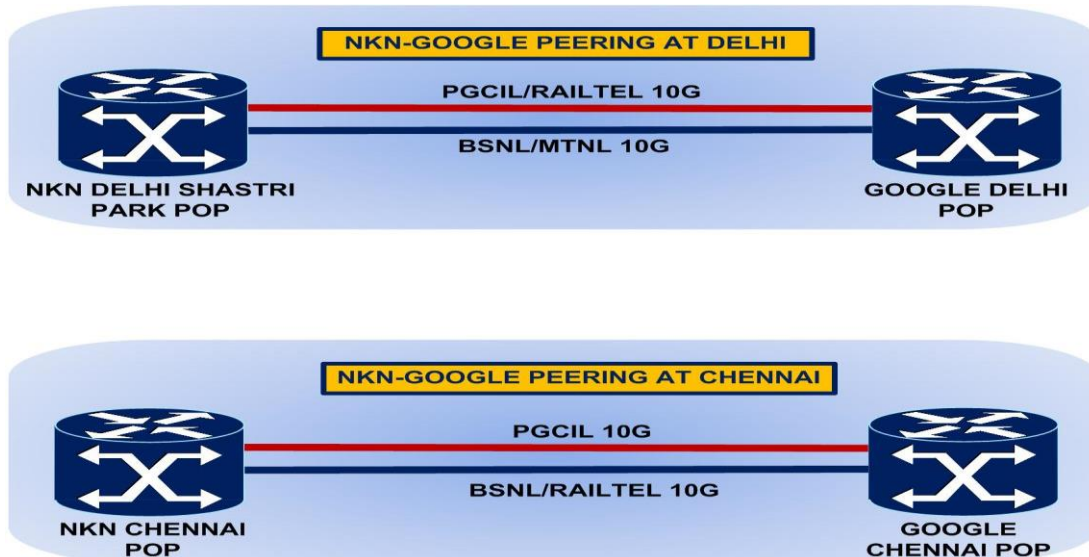

1. Rate contract of NKN already in place with NLDs like BSNL/RAILTEL/PGCIL  
10 Gbps for 10 years (120 months): Intracity or < 250Kms = Rs 2.26 Crores
2. For period between July 2014 till December 2019 (coterminous with NKN period) (66 months)  
Cost for this period per link:  $(2.26 \times 66) / 120 = \text{Rs } 1.243 \text{ Crores}$   
Cost for 4 links =  $1.243 \times 4 = \text{Rs } 4.972 \text{ Crores}$   
Customer premises equipment = Rs 1.5 Crores approx.  
Service Tax @ 12.36% = Rs 80 Lakhs approx.  
**Total = Rs 7.272 Crores approximately**
3. For five year period, the 10 Gbps Internet Connectivity will cost Rs. 150 crores. Thus we will be saving Rs. 142.8 Crores (Rs. 150 Crore – Rs. 7.2 Crore).

The proposal was discussed in the meeting of the Implementation-cum-Monitoring Committee of NMEICT on dated 16.06.2014; the committee has recommended the proposal. As recommended by the committee, the proposal has been made coterminous with NKN.

The above proposal of NKN/ NMEICT Direct Peering with Google at a cost of Rs. 7.272 crores with NIC as implementing agency is placed before the PAB of NMEICT for consideration and its approval.

**Agenda Item No. - 10**

**Special Permission to NIT  
Sikkim for 1 Gbps Connectivity.**

## **Agenda Item No. 10**

**Proposal** : **Special Permission to NIT Sikkim for 1 Gbps Connectivity.**

**Implementing Agency** : **BSNL**

### **10.1 Background**

Under the National Mission on Education through Information and Communication Technology (NMEICT) connectivity to over 25000+ colleges and 2000 polytechnics in the country and 419 universities/deemed universities and institutions of national importance are being provided. LAN of up to 400 nodes on average is also being provided to the universities. As on May 2014, 403 universities and nearly 21000 colleges in the country have been connected under the Mission. BSNL has provided connectivity to the NIT Sikkim on 31.03.2012. Since the date of provisioning, various complaints have been received from NIT Sikkim of the poor connectivity of 1 Gbps link provided by BSNL under NMEICT.

The issue of connectivity has also been discussed in the Conference of the Vice Chancellors of the Central Universities and of the Directors of the National Institute of Technology last year at Rashtrapati Bhawan, New Delhi. One the recommendation was to provide alternate, back-up links (from BSNL/ RailTEL/ Powergrid) and Telecom PSUs should ensure continuous availability of bandwidth.

### **10.2 Proposal**

BSNL was pursued to take all necessary action to improve the uptime of the 1 Gbps link provided to the NIT Sikkim. In response BSNL has proposed that if linear connectivity provided to NIT Sikkim is converted to a ring and some portion of the OFC route is repaired then uptime of the 1 Gbps link can be increased to 75%. The proposal submitted by the BSNL is depicted in the diagram (Page : 21) below:

### LINE DIAGRAM OF STM-16 MADM

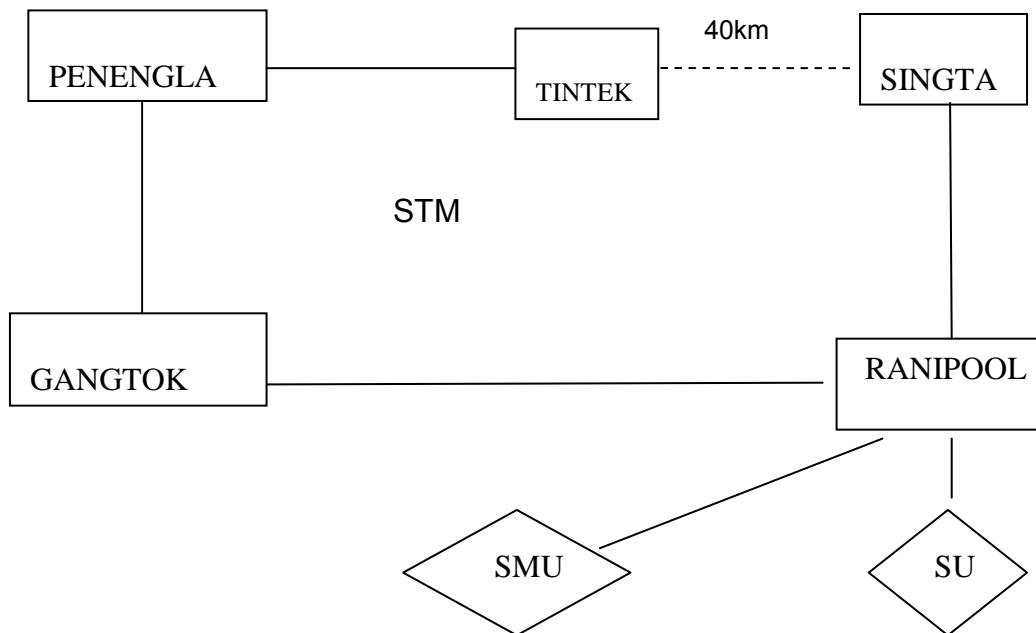
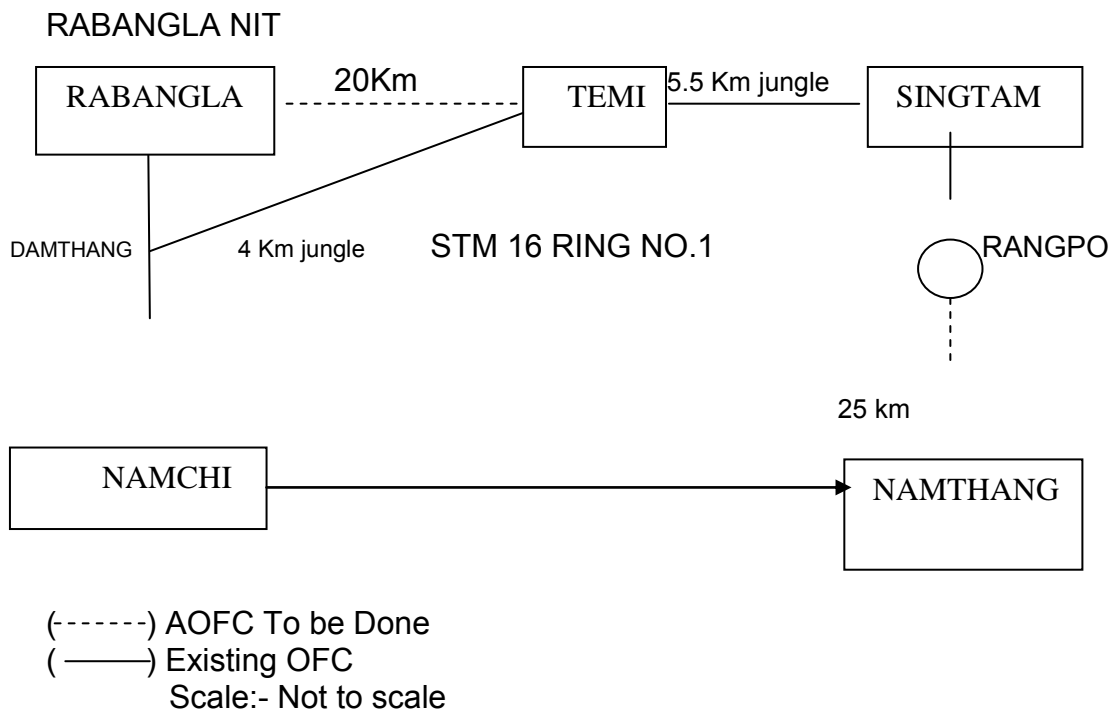

Through the proposal submitted BSNL has said that to complete the ring, new OFC is required to be laid between Rabangla – Temi (20 Km.) and between Rangpo – Namthang (25 Km.) Further the OFC route between Tintek – Singtam (40 Km.) is required to be repaired. BSNL has submitted the estimate and sated that it is ready to provide OFC ring connectivity to NIT Sikkim provided MHRD pay an amount of Rs. 291.527 lakhs and sought MHRD’s approval.



### 10.3 Financial Implication

The details of the cost estimation submitted by BSNL are as follows:

**(i) Estimate for Rabangala – Temi, 12 AOFC Scheme:**

Item	Cash	Store	Overhead	Stm-16	Total (Rs.)
Land	0	0	0		0
Building	0	0	0		0
E.I.	0	0	0		0
Cable	2487067	2134681	0		4621748
A & p	195691	0	0	5508579	5704270
M. Vehicle	989211	0	0		989211
D & e	1022820	0	0		1022820
Total	4694789	2134681	0		12338049
SAY				5508579	12338000
<b>Total Cash (in Lakhs) say:</b>					<b>123.380</b>

**(ii) Estimate for Namthang - Rangpo, 12 AOFC Scheme:**

Item	Cash	Store	Overhead	Stm-16	Total (Rs.)
Land	0	0	0		0
Building	0	0	0		0
E.I.	0	0	0		0
Cable	3099660	3100170	0		6199830
A & p	195691	0	0	5508579	5704270
M. Vehicle	989211	0	0		989211
D & e	1022820	0	0		1022820
Total	5307382	3100170	0		13916131
SAY				5508579	13916000
<b>Total Cash (in Lakhs) say:</b>					<b>139.100</b>

**(iii) Estimate for Tintek - Singtam for AOFC to be replaced in existing scheme:**

Item	Cash	Store	Overhead	Stm-16	Total (Rs)
Land	0	0	0		0
Building	0	0	0		0
E.I.	0	0	0		0
Cable	1432867	1471904	0		2904771
Say		0	0		2904771
<b>Total Cash (in Lakh) say:</b>					<b>29.047</b>
<b>Grand Total (i)+(ii)+(iii) : Rs. 291.527 lakhs</b>					

A copy of the letter received from the BSNL is at **Appendix-VI / Pages: 105 to 113.**

**The proposal was discussed in the meeting of the Implementation-cum-Monitoring Committee of NMEICT on dated 16.06.2014; the Committee has recommended the proposal.**

**The above proposal of special permission to make OFC Ring of 1 Gbps Connectivity provided under NMEICT to NIT Sikkim at a cost of Rs. 291.527 lakhs (Rs. Two Crore Ninety One Lakh Fifty Two Thousand Seven Hundred only) is placed before the PAB of NMEICT for consideration and its approval.**

**Agenda Item No. - 11**

**1 Gbps Connectivity to the  
New Private Universities.**

## **Agenda Item No. 11**

### **Proposal: 1 Gbps Connectivity to the New Private Universities.**

#### **11.1 Background**

National Mission on Education through Information and Communication Technology (NMEICT) was approved by the Cabinet Committee on Economic Affairs (CCEA) on the 2<sup>nd</sup> January, 2009. In the Mission it was envisaged that it would extend computer infrastructure and connectivity to over 18,000 Colleges and 419 Universities in the Country on a single point rental basis permitting their seamless integration in the integrated National Knowledge Network (NKN). This Connectivity was perceived on Copper Wire.

In the NKN Project, later on, it was decided to connect important institutions and universities on Optical Fibre Cable (OFC). In view of the mandate of CCEA for seamless integration with NKN, it was decided that the Connectivity to Universities and Institutions of National Importance may be provided on OFC on the rates and pattern approved by NKN during pilot project. Accordingly this Ministry has taken approval of the Cabinet on 01.11.2011 through a Note containing the proposal for achieving convergence and synergy between NMEICT and NKN and other issues. The cabinet has, inter alia, approved the following:

- i) Shifting the Technology from Copper Wire based Connectivity to Optical Fibre Cable (OFC) based Connectivity in respect of already connected Universities/ University Level Institutions ex post facto and Connecting the remaining Universities/ University Level Institutions on OFC with provisioning of 400 nodes LAN on an average to every University/ University Level Institution (including private universities) and Providing Connectivity to 25000+ Colleges and 2000 Polytechnics.
- ii) Raising the number of Universities and Institutions of National Importance to be provided Connectivity (utilizing NMEICT and NKN) from 419 to 572 (419 under NMEICT and 153 under NKN).
- iii) Installation of Routers and Switches as part of LAN in all Universities in NMEICT List as per the specifications indicated by NKN.

## 11.2 Present Status

Under NMEICT, so far Connectivity to 403 Universities and nearly 21000 Colleges in the Country has been provided. The LAN of upto 400 nodes has also been implemented by BSNL in the 50 Universities.

National Information Centre (NIC) has time and again intimated that their mandate is to provide the connectivity to the public institutions only. The list of 153 universities/ university level institutions provided to NIC for the Connectivity under NKN contained the public and private Universities/ University Institutions both. NIC has connected only Public Universities. The Private Universities in the list are pending. A list of such Universities is available at **Appendix-VII/ Pages: 114 to 115**. There are about 38 such Universities.

From a report obtained from the University Grants Commission (UGC) it has been understood that the number of Universities in the Country has increased to 658 since the last approval of the Cabinet. A list of new Universities added during the period is at **Appendix-VIII / Pages: 116 to 123**. The list includes the Public and Private Universities both. There are 53 Central/ State Universities and 98 Deemed/ Private Universities.

Further there are 14 Centrally Funded Institutions (CFIs) where 1 Gbps OFC Connectivity may not be available. The list of such CFIs is at **Appendix- IX / Page: 124**.

## 11.3 Proposal

As the NMEICT Mission is designed to address the issue of access, equity and quality, it is necessary to provide the connectivity to all the Universities/ University Level Institutions in the country treating public or private equally. Considering this it is proposed that all pending Central/ State Universities may be connected under NKN and remaining Deemed/ Private Universities may be connected under NMEICT. There are about 53 Central/ State Universities (new list will be forwarded to NKN after due approval) and 136 Deemed/ Private Universities (including pending private universities to be connected under NKN). The connectivity to CFIs may also be

considered to be provided under NKN. The funding pattern to these universities will remain the same as already approved for the respective schemes of NKN and NMEICT. In case of NMEICT Universities, NIC will be asked to implement the connectivity through the service providers like BSNL/ Railtel/ PGCIL as NIC has already MoU with them. The MHRD will pay to the service providers as decided by the NIC.

#### **11.4 Financial Implications**

Rate as approved under NMEICT scheme for providing 1 Gbps OFC Connectivity for 10 years = Rs. 1.8 crores (Rs 2.0 Crores – 10% discount from BSNL). The funding pattern under the Mission is 75:25 i.e. 75% by Central Government and 25% by the State/ University/ Institution concerned. Thus the share of the Central Government is Rs. 1.35 crores (75% of Rs. 1.80 Crores). Considering that connectivity is to be coterminous with the time frame of NKN i.e. December 2019, only 5 years are left. The charge for 5 years will be Rs. 67.5 lakhs  $\{1.35 \text{ Crores} \times 5 / 10 = 0.675 \text{ Crores}\}$  per University/ University Level Institutions. For 136 Universities/ University Level Institutions the charges for 5 years will be Rs. 91.8 crores  $\{136 \times \text{Rs } 0.675 = \text{Rs.}91.8 \text{ crores}\}$ .

**The proposal was discussed in the Meeting of the Implementation-cum-Monitoring Committee of NMEICT on dated 16.06.2014; the committee has recommended the proposal. The committee has also recommended that connectivity to all Government/ State Universities and Centrally Funded Institutions may be provided under NKN. The Connectivity to the New Private Universities/ University Level Institutions may be provided under NMEICT.**

**Accordingly the above proposal of providing 1 Gbps Connectivity to the New Private University/ University Level Institutions under NMEICT at a cost of Rs. 91.8 Crores (Rs. Ninety Crore Eighty lakhs only) is placed before the PAB for consideration and its approval.**

**Agenda Item No. - 12**

**Develop an Online Joint  
Entrance Examination (Main)  
(JEE) Item Bank to Prepare  
Candidates for Developing the  
Skills that Underpin  
Performance on the JEE (Main)  
Construct.**

**PI: Mr Vineet Joshi, Chairman CBSE.**

## Agenda Item No. 12

- Proposal** : **Develop an Online Joint Entrance Examination (Main) (JEE) Item Bank to Prepare Candidates for Developing the Skills that Underpin Performance on the JEE (Main) Construct**
- PI** : **Mr Vineet Joshi, Chairman CBSE, [director@indiaqaer.in](mailto:director@indiaqaer.in) , [vineetgre@yahoo.co.in](mailto:vineetgre@yahoo.co.in) 8527244005**
- Organization** : **Central Board of Secondary Education, New Delhi (through CBSE-CAER)**

The CBSE, through CAER, a PPP initiative of the Board, is proposing to develop an item bank of JEE (Main) items which students preparing for the JEE can access online for self learning and remediation. These items will be linked to learning materials which are designed to help students improve their learning.

In essence the project would involve identifying up to 500 JEE (Main) or AIEEE items from previous administrations; item writers listing rationales besides each incorrect option (that is what incorrect strategy is causing the incorrect response); identifying corrective learning strategies for each of the incorrect options; and then providing the candidate with a further 5 items assessing the same skill as that being assessed by the item which elicited an incorrect response.

Eventually all candidates would have access to this powerful “learning” tool for a minimum cost. This addresses some of the concerns outlined above in that the focus is on learning. The assessment is designed to identify areas of potential weakness; promulgate corrective strategies that have been identified through an analysis of the assessment items; and, give further practice examples from similar JEE items which assess the same skill to make sure that the student has understood the concept. In the first year or two of the establishment of the item bank (learning tool) the feedback will be in written form. However, ultimately the intention would be to utilise multimedia tools to make the learning more interactive.

It is expected that all students from across India (and internationally) would have access to the item bank online. In addition, it would be expected that the cost of using such a test preparation tool would be very small; in accord with the requirement to minimise the gaps between those who can afford test preparation training and those who cannot.

CBSE/CAER had first given the detailed presentation to SC on 03.03.2014 on their Project, and the recommendations made by SC as follows:

*“The Chairman observed that the idea behind this proposal is wonderful. However, after discussions, it was decided that PI to revise the proposal incorporating the following observations and re-submit/ upload on Sakshat:*

- a) Financial requirements have to be looked into depth by PI giving detailed justifications/ rationale and unit costs etc. Some cost heads may need serious review, e.g. Overhead Costs, which are not admissible.*



- b) *The revised proposal may be prepared using the structured format for all uploaded proposals.*
- c) *Dr. C. S. Arora, Senior Consultant (NMEICT) offered to send them the format to facilitate the PI before uploading their revised proposal on Sakshat.*
- d) *PI may present the revised proposal in next SC meeting. “*

CBSE/CAER then submitted their revised detailed Project Proposal in the prescribed format on 23rd May 2014 for consideration by SC in next meeting held on 28<sup>th</sup> May 2014. As per the revised proposal PI has indicated that there are **four major deliverables** in the project:

- 1) The table of specifications developed by experts on the basis of previous JEE Examination Papers.
- 2) A question bank consisting of 501 items mapped to each specification and an expanded set of items increasing the number of items per specification to 10.
- 3) Learning material or content linking concepts to questions and their answer options.
- 4) An Online Platform in the form of a website where students can access the Resources.

For above deliverables, PI asked for Total Cost of Rs. 1.59 Crores for 2 years (Non-recurring Rs. 1,21,00,000/- and Recurring 38,00,000 for next year).

**In the meeting held on 28.05.2014, SC recommended the project for PAB's approval after getting the financial due diligence done by a third party agency.** SC also recommended that while awarding the job to CBSE, they should be conveyed the following:

- i) CBSE has to ensure that if they go for outsourcing of Software development, then no rights will be retained by the Outsourced Agency.
- ii) Any arrangement for charging for the use of Software/contents by students will be done with the consent of MHRD/NMEICT.

Subsequently, NMEICT got this project proposal reviewed for financial due-diligence by independent expert agency KPMG. In their report (attached), KPMG reviewed with PI's team the Project scope, duration, budget and other parameters, etc., and after their review they **recommended reduction of cost from Rs. 1.59 Crore to Rs. 1.23 Crore**. After their interaction with KPMG, PI then revised further and finalized the proposal for the agreed total cost of Rs. 1.23 Crore (Rs. 90 lakh non-recurring + Rs. 33 lakh recurring) for this Project. The finally revised DPR from CBSE received on 19<sup>th</sup> June 2014 is also attached.

**PAB may consider approval of the Project for 2 years with a Total Budget of Rs. 1.23 Crore as recommended by KPMG after Financial Due Diligence.**

**Agenda Item No. - 13**

**Consulting Work for preparing a  
Project Report for Creation of  
“Virtual University” in PPP model  
and draft “Virtual University Bill” for  
enactment by Parliament.**

PI: Mr Siddhartha Das, Executive Director,  
Ernst & Young LLP, Gurgaon

### **Agenda Item No. 13**

- Proposal** : **Consulting work for preparing a Project Report for Creation of “Virtual University” in PPP model and draft “Virtual University Bill” for enactment by Parliament**
- PI** : **Mr Siddhartha Das, Executive Director; 91-9831014940, 91-124-464 4000, [siddhartha.das@in.ey.com](mailto:siddhartha.das@in.ey.com)**
- Institution** : **Ernst & Young LLP, Gurgaon.**

MHRD is encouraging usage of technology initiatives in higher education and to make the benefits of technology-enabled learning (TEL) available for wider access and equity for all of about 2.6 Crore students in higher education. Technology-enabled learning has the potential to leverage appropriate pedagogy for e-learning, providing facility of performing experiments through virtual laboratories, on-line testing and certification, on-line availability of teachers to guide and mentor learners, utilization of Direct to Home platforms, training and empowerment of teachers to effectively use the new method of teaching learning etc.

To leverage TEL to its maximum potential with prevalent systems and contemporary technologies, it is envisaged to establish a “Virtual University” (VU) in India. The benefits envisaged for starting VU are as follows:

- i) Access to variety of Courses for all students across the country to get Degree in the Topic of their choice.
- ii) An opportunity to enhance Skills anytime anywhere.
- iii) Students can choose to do multiple Courses at the same time.
- iv) Students to have options from a long list of Topics for optional Subjects.
- v) Recognition / credits to Enhance Credibility.
- vi) Interdisciplinary Courses can be offered.
- vii) Makes students Industry ready.
- viii) Vocational Training can be offered.
- ix) Opportunity to Streamline Curriculum and Content.
- x) Ability to adapt to market changes in Short Period of Time.
- xi) Enable credit transfers between Virtual and Physical Universities.
- xii) Can address Shortage of Staff.

To start with, this university may provide education to all teachers of engineering colleges, polytechnics and other management institutions not having the doctoral degree. The education will be imparted using modern technology of satellite and Internet. The students will be able to credit courses during the semesters even when they are teaching in their colleges as well. Thus, to start with, VU will be focusing on post-graduate education for teachers. The university will offer courses of flexible credit hours. Each course will have assignments as well as examinations, including provision for “virtual class participation”. Based on the credits acquired by students, it is possible to award either a certificate or a diploma or a degree. This will allow for many professional working in industry to join the university to be set up in PPP model. Thus, the target population of students is not simply teachers but professional engineers, managers as well as supervisors. To start with, the minimum qualification for entry into VU shall be a Bachelor’s degree.

Eventually, the VU will not only offer courses in technical fields but will also cover the subjects of management, humanities, commerce and arts streams etc. The university will follow an academic calendar of three semesters per year each semester of four-month duration.

The University governance and operation can be based on the following premises:

- i) Students to be given option of choosing Topics outside their Curriculum.
- ii) Encourage Interdisciplinary Education.
- iii) Typical course to run along side the Regular Semester.
- iv) Transfer of Credits.
- v) Use centralized Exam / Evaluation Platforms.
- vi) Use external agencies to Manage Credits and Ranking.
- vii) Focus on all round development of the Student.
- viii) Enable industry exposure through Internships / Projects.

With above background, a Request for Quotation for consulting work for preparing a Detailed Project Report for Creation of Virtual University in PPP model and draft “Virtual University Bill” for enactment by Parliament was sent by mail on limited basis by NMEICT on June 2, 2014 to the following organisations listed as Transaction Advisors under MoF for PPP projects:

- |                       |                      |
|-----------------------|----------------------|
| 1) Abacus Legal Group | 7) Feedback Ventures |
| 2) Grant Thornton     | 8) KPMG              |
| 3) Crisil             | 9) Deloitte          |
| 4) E&Y                | 10) IL&FS            |
| 5) PwC                | 11) IFC              |
| 6) IDFC               | 12) RITES            |

The request for bids specified the scope of consulting work to be undertaken comprising of the following 3 Deliverables:

**Deliverable 1:**

Preparation of a **Detailed Project Report (DPR) for Creation of Virtual University in PPP model** for approval by MHRD.

**Deliverable 2:**

Preparation of a **Draft “Virtual University Bill” for enactment by Parliament** for further examination by concerned MHRD Bureaus.

**Deliverable 3:**

**Draft Cabinet Note** (including justification) for inter-ministerial consultations prior to seeking Cabinet approval for piloting the VU bill in parliament

A pre-bid meeting of the interested bidders was held for giving clarifications on RFQ on **6<sup>th</sup> June 2014** in the chamber of JS (TEL) & Mission Director (NMEICT).

Representatives of the following organizations attended:

- i) E&Y (Sl. No. 4 of above list)
- ii) KPMG (Sl. No. 8 of above list)
- iii) Deloitte(Sl. No. 9 of above list)

By last date 12<sup>th</sup> June 2014, 3 Bids were received from above, which are as follows:

- 1) Ernst & Young: Rs. 28.0 lakh (including out of pocket expenses) + Service Tax; Time: 24 weeks
- 2) KPMG: Rs. 29.5 lakhs + out of pocket expenses on actuals + Service Tax; Time: 22 weeks
- 3) Deloitte: Rs. 198.08 lakhs (including out of pocket expenses) + Service Tax; Time: 6 months.

It was decided to call the lowest bidder - Ernst & Young - in Mission Director's chamber for cost negotiation and confirmations on scope of work and time to be taken, etc. Subsequent to the meeting held on 19<sup>th</sup> June 2014, E&Y sent written confirmation on 20<sup>th</sup> June 2014 on the following:

- 1) The revised bid cost after negotiations is agreed by them to **Rs. 24.9 Lakhs** (including out of pocket expenses) + Service Tax will be applicable.
- 2) E&Y will try to complete the assignment within 5 months, but in no case later than **6 months** after award of work.

3) E&Y agreed to the following payment schedule:

- i) 40% payment on submission of the first deliverable
- ii) Balance 60% on submission of the 2<sup>nd</sup> and 3<sup>rd</sup> deliverable

**PAB may consider and approve for award of the Consulting Work for preparing a Detailed Project Report for Creation of Virtual University in PPP model and draft “Virtual University Bill” for enactment by Parliament with 3 deliverables mentioned above within 6 months, to M/s Ernst & Young at the total cost of Rs. 24.9 lakhs (including Out of Pocket Expenses) + Service Tax, with payment schedule agreed as above.**

**Agenda Item No. - 14**

**Consulting Work for Review and  
Amendment of applicable  
UGC/AICTE Regulations for  
Incorporating Technology Enabled  
Learning in Higher Education.**

PI: Mr Akshoy Rekhi, Abacus Legal Group, New Delhi

## Agenda Item No. 14

- Proposal** : **Consulting work for Review and Amendment of applicable UGC/AICTE Regulations for incorporating Technology Enabled Learning in Higher Education.**
- PI** : **Mr Akshoy Rekhi, Partner; Phone: 91-11-41633366/65/64**
- Institution** : **Abacus Legal Group, Advocates; New Delhi.**

MHRD is encouraging usage of technology initiatives in higher education and to make the benefits of technology-enabled learning available for wider access and equity for all of about 2.6 Crore students in higher education. Technology-enabled learning (TEL) has the potential to leverage appropriate pedagogy for e-learning, providing facility of performing experiments through virtual laboratories, on-line testing and certification, on-line availability of teachers to guide and mentor learners, utilization of Direct to Home platforms, training and empowerment of teachers to effectively use the new method of teaching learning etc.

For exploring the feasibility and enforcement of Technology Enabled Learning in Higher Education through UGC Regulations -- aimed at wider deployment of TEL, a Request for Quotation for consulting work for "Review and Amendment of applicable UGC Regulations for incorporating Technology Enabled Learning in Higher Education" was sent by mail on limited basis by NMEICT on 5th May 2014 to the following organisations:

- |   |   |
|---|---|
| 1) Abacus Legal Group                   | 8) KPMG   |
| 2) Grant Thornton                       | 9) Deloitte                                       |
| 3) Crisil (and its research arm Irevna) | 10) IL&FS   |
| 4) E&Y                                  | 11) Commonwealth of Learning                      |
| 5) PwC                                  | 12) IIT Kharagpur (Rajiv Gandhi School of IP Law) |
| 6) IDFC                                 |   |
| 7) Feedback Ventures                    | 13) NALS&R  |

The request for bids specified the scope of consulting work to be undertaken in about 3 months, comprising of the following 2 Deliverables:

### **Deliverable 1:**

Preparation of a Detailed Background Policy Note for enforcement of Technology Enabled Learning in Higher Education through amendment of applicable UGC Regulations.

### **Deliverable 2:**

Review and amendment of applicable UGC Regulations for incorporating Technology Enabled Learning in Higher Education for further examination by concerned MHRD Bureaus.



By last date 20<sup>th</sup> May 2014, only 2 Bids (from Abacus Legal Group and KPMG Sl. No. 1 & 8 respectively from above) were received out of above. However another unsolicited bid was also sent by an agency ETMA (to whom NMEICT had not sent RFQ), on reference from one of the invitees, which was not considered further.

The two bids received out of the above list of 13, are as follows:

- 1) Abacus Legal Group: Rs. 9,00,000/- exclusive of Service Tax.
- 2) KPMG: Rs. 12,80,000 exclusive of Service Tax + Out of pocket expenditure on Actuals

It was decided to call the Lower bidder – Abacus Legal Group – in Mission Director’s chamber for cost negotiation and confirmations on scope of work and time to be taken, etc. Subsequent to the meeting held on 30<sup>th</sup> May 2014, Abacus Legal Group has sent written confirmation on the following:

- i) The bid cost of Rs. 9 lakhs will be inclusive of Service Tax.
- ii) The Scope of work will also include the legislations passed by AICTE apart from UGC.
- iii) The time period of 3 months after the award was confirmed.

In the meeting, Abacus requested for Mobilisation Advance of 20% for which they furnished documentary proofs of the similar provision agreed by 3 clients from Government sector.

**PAB may consider and approve for award of the Consulting Work for Review and Amendment of applicable UGC/AICTE Regulations for incorporating Technology Enabled Learning in Higher Education, to M/s Abacus Legal Group Advocates at the total cost of Rs. 9 lakhs, with 20% Mobilisation Advance on award of the work and remaining 80% after satisfactory receipt of 2 Deliverables.**

**Agenda Item No. - 15**

**Setting up and Providing VPN  
Connectivity to 200 ITIs under  
Director General, Employment  
and Training (DGET),  
Ministry of Labour and  
Employment (ML&E)  
Government of India.**

## **Agenda Item No: 15**

### **Setting up and providing VPN Connectivity to 200 ITIs under Director General, Employment and Training (DGET) Ministry of Labour and Employment (ML&E) Government of India.**

Director General, Employment and Training (DGET) Ministry of Labour and Employment (ML&E) Government of India, vide letter dated 23<sup>rd</sup> & 30<sup>th</sup> April 2014 has stated that ML&E has decided to start training trainers in distance learning mode. In this regard, DGET is in process to set up 10 Hubs at DGET, field Institutes & 200 Spokes in ITI's throughout the country. Action has been initiated by ML&E to set up 200 Spokes by Mid June 2014 and Studio at 10 Hubs is likely to set up around November 2014. The DGET, ML&E has requested the Ministry of Human Resource & Development to provide Internet Connectivity to its Training Institutions numbering 200 spread across the country.

It may be recalled, the NMEICT has a centrally sponsored scheme to provided (i) 10 Mbps VPN connectivity to colleges and (ii) 20 Modems for Wi-Fi connectivity at each college. The connectivity has been installed through BSNL & MTNL and so far approximately 21,000 colleges have been provided with the connectivity under the scheme. The scheme is a subsidized one, with 75% share to be provided by the Centre/MHRD and 25% by the Institution for installation and operations of VPN, for a period of ten years.

It is to put up for consideration of PAB.

- a) The VPN connectivity Scheme of NMEICT to Colleges be extended to institutions under DGET, ML&E till XII<sup>th</sup> Five Year Plan.
- b) 200 Training Institutions situated at ITI's under DGET, ML&E to be provided VPN connectivity, with 75% share to be provided by MHRD and 25% by the Institutions/ DGET, ML&E, for installation and operations, for a period of ten years, at the rate that is prevailing under NMEICT.

**PAB may consider approval for setting up and providing:**

- i) **VPN Connectivity to 200 ITI's under DGET, ML&E upto March 31, 2017.**
- ii) **The financial implication of the Project is Rs. 4.00 Crore.**

**Agenda Item No. - 16**

**Office Space for  
Mission Secretariat  
NMEICT.**

## Agenda Item No. 16

### Office Space for Mission Secretariat NMEICT.

- 1) Since the inception of National Mission on Education through Information & Communication Technology (NMEICT) in February, 2009, the Mission Secretariat of NMEICT for the past five years does not have its regular office & hence had to be relocated four times to IGNOU, Curzon Road Barracks, R.K. Puram & again back to IGNOU.

The Consultants of NMEICT expected to interact with PIs all over the country are presently accommodated in an small old MHRD' Library at Shastri Bhawan whereas; the existent space available at Shastri Bhawan, MHRD is not adequate enough for all the Mission Project Officials & Consultants to function from a common location. The co-ordination between the Bureau Officials / Consultants, TSG-EdCIL also gets hampered since the project Officials / Consultants are scattered all over at IGNOU, NIOS, Shastri Bhawan & EdCIL's Corporate Office, NOIDA.

- 2) For enabling collaborative working and better development and integration of the services offered by the Mission to students and other stake-holders all over India, it would be ideal if the project personnel of Virtual University, DTH, representatives of major projects and all the Staff of Mission Secretariat including Sakshat Portal Team function from common premises. This shall also facilitate to optimally utilize the resources of the Mission.

The added advantage of the Common Infrastructure shall result in Enhanced Coordination, Economizing Operational Cost and Better Services besides Sharing of IT Facility and Ensuring Coordinated Connectivity.

- 3) In order to address these hardships, the Joint Secretary (TEL) & Mission Director (NMEICT) has been exploring the possibilities of availing office space from the various Government organizations. The senior Bureau officials of MHRD visited various Government Departments and inspected the under mentioned available spaces:

- i) NDMC Building, Parliament Street, New Delhi.
- ii) Samrat Hotel, Chanakya Puri, New Delhi.
- iii) West Block, R. K. Puram, New Delhi.
- iv) MTNL Building, Minto Road, New Delhi.
- v) DMRC Buildings at the Shastri Park, New Delhi.

The Buildings at S.No. (i) to (iv) were found to be not suitable to meet the office requirements of the Mission.

- 4) As providing of Connectivity to all Colleges and Universities is one of the major components of the Mission and for this purpose, the Mission's officials & Consultants have to regularly interact with NKN & National Data Centre (NDC) of NIC, which is located at DMRC Building in the Shastri Park. As such, the DMRC building located at Shastri Park has been found to be prima facie most suitable to accommodate all the Mission staff at a common place. The Joint Secretary (TEL) & Mission Director (NMEICT) met Managing Director, DMRC Ltd on 23<sup>rd</sup> May, 2014 to explore the possibilities of availing office space from them [ Refer letter dated 19.05.2014 at Appendix-X ].

The MTNL's letter No. DMRC/PD/L-1/ITP/780 dated 27.05.2014 offering space for Mission is placed at Appendix-XI for kind perusal.

The following areas are available for leasing at IT Park :

S.No.	Block	Floor	Area
i)	3	Ground Floor	1245 sqm
ii)	3	Ground Floor	1174 sqm
iii)	1	5 <sup>th</sup> Floor	526 sqm

To finalize the issue, the site inspection of the various locations from the options available of DMRC buildings at Shastri Park was undertaken by the Joint Secretary & Mission Director (NMEICT) on 30<sup>th</sup> May, 2014.

Out of the 3 available options at DMRC buildings at Shastri Park, the following premises has been found to be most suitable to cater to the requirements of NMEICT:

Block	Floor	Area	Remarks
1	5 <sup>th</sup> Floor	526 sqm	DITP B Wing Side, DMRC IT Park, Shastri Park, Delhi 110053. [Previously occupied by Apollo Munich]

The proposed office building is almost in ready to occupy state with least refurbishing & redesigning of space. The space is readily available to cater for Conference Room, Meeting Room, Mission Director's cabin, workstations for project personnel & Consultants, etc.

The Joint Secretary & Mission Director (NMEICT) concurrence for one of the Office Space at DMRC Building, Shastri Park, New Delhi is placed at Appendix-XII (Letter No. F.No. 8-42/2013-TEL dated 04.06.2014).

- 5) This item was also placed before the Standing Committee in its Meeting held on 27<sup>th</sup> & 28<sup>th</sup> May, 2014. The extract of the Minutes of the said meeting are as follows:

*“The Joint Secretary (TEL) & Mission Director (NMEICT) has been authorized by SC to look at the options available for Office Space for Mission Secretariat of NMEICT and initiate the processes for acquiring Office Space NMEICT Mission Secretariat at the earliest”.*

- 6) The DMRC Ltd representative has been invited for the meeting of PAB to confirm the concurrence of DMRC Ltd for one of the available Office Space at Shastri Park, New Delhi so that Lease Rent and other terms & conditions can be for a better deal with DMRC Ltd:

PAB is requested to consider to authorize Joint Secretary (TEL) & Mission Director (NMEICT) to identify a suitable location at DMRC complex at Shastri Park, New Delhi and initiate the process of negotiating lease rent and other terms & conditions for a better deal with DMRC Ltd.

**Submitted for perusal and kind consideration of the PAB.**

**Agenda Item No. - 17**

**Budget Estimate for  
TSG-EdCIL & Mission  
Secretariat of NMEICT  
for  
Financial Year 2014-15.**



## **Agenda Item No. 17.**

### **Budget Estimate for TSG-EdCIL & Mission Secretariat of NMEICT for the Financial Year 2014-15.**

The Department of Higher Education, Ministry of HRD has entered into a Service Agreement with EdCIL (INDIA) Limited to establish & maintain a Mission Secretariat for the National Mission on Education through Information and Communication Technology (NMEICT). The Mission Secretariat comprises of a Technical Support Group (TSG-EdCIL), Consultants and the Support Staff dedicated to the Scheme.

The TSG-EdCIL has engaged Consultants and dedicated Support Staffs for the Mission Secretariat to facilitate the Bureau of Department of Higher Education, MHRD for implementation of the Scheme. These Consultants of Mission Secretariat provides technical support to the Bureau.

The TSG-EdCIL maintains and supports the Mission Secretariat besides also facilitates to organize Dissemination Workshops & Meetings viz. *National Apex Committee, Project Approval Board, Standing Committee, DTH Committee, Implementation-cum-Monitoring Committee & all other meetings under NMEICT Scheme* apart also makes on the spot payments for Travelling Allowance/ Honorarium to the members/invitees/experts/participants of these Workshops/ Meetings.

The Budget Estimate for the TSG-EdCIL & Mission Secretariat of NMEICT for the year 2014-15 has been estimated through a consultative process for a total amount of ₹ 399.92 lakhs including Non-recurring Expenditure of ₹ 28.36 lakhs, Recurring Expenditure of ₹ 305.62 lakhs and EdCIL's overhead & Service Charges of ₹ 16.95 lakhs, except relocation of office premises, refurbishing, renovation, rental, security, electricity, water charges maintenance, housekeeping for the proposed new office premises of Mission Secretariat, etc as per the summarized details enclosed at Annexure-I / Page: 41. Service Tax will be charges to MHRD at the applicable rates, on actual total expenditure. At present, Service Tax @12.36% is leviable on total expenditure (non-recurring, recurring & EdCIL's overhead & Service Charges). The detailed Budget Estimate is placed at Annexure-II/ Pages: 42 to 45.

Permission is also sought in respect of re-allocation of expenditure under the budgeted heads of the aforesaid Budget Estimate.

The un-utilized funds, if any, will be carried over to the next financial year to meet the expenses on activities of TSG –EdCIL & Mission Secretariat of NMEICT.

The Budget proposed for the year 2014-15 for the TSG-EdCIL & Mission Secretariat of NMEICT is well within the overall ceiling of 1% of the total outlay fixed for the Project.

The Project Approval Board (PAB) is requested to consider and approve "Budget Estimate" of ₹ 399.92 lakhs for the Mission Secretariat for the year 2014-15 and consider to release the 1<sup>st</sup> installment of ₹ 199.96 lakhs (being 50% of the total Budget) after adjusting the unspent amount available with EdCIL.

## Annexure-I

### Budget Estimate for TSG-EdCIL/Mission Secretariat of NMEICT for the Financial Year 2014-15.

S. No.	Description of the Item	Total Cost (Rs.In lakhs)
<b>I) NON-RECURRING EXPENDITURE</b>		
<b>Office Expenses</b>		
A	Office Expenses - Procurement of IT items & Mobile Phones	13.23
B	Office Expenses - Procurement of Softwares	1.50
C	Office Expenses - Procurement of Office Equipment	3.45
D	Office Expenses - Procurement of Furniture	10.18
	<b>Sub-total (Non-recurring expenditure)</b>	<b>28.36</b> .....(I)
<b>II) RECURRING EXPENDITURE</b>		
A	Professional Services	140.68
B	Salary & Wages	46.24
C	Over Time Allowance	1.50
D	Domestic Travel Expenses	41.00
E	Other Administrative Expenses	45.00
F	Publications	10.00
G	Office Expenses	21.20
	<b>Sub-total (Recurring expenditure)</b>	<b>305.62</b> .....(II)
	<b>Total</b>	<b>333.98</b> .....(a)
	[Non- recurring expenditure(Rs.28.36)+Recurring expenditure (Rs. 305.62)]	
	Contingency on (a) [ <b>Lumpsum Provisions</b> ]	5.00
	<b>Sub-Total</b>	<b>5.00</b>
	<b>Total</b>	<b>338.98</b> ....(b)
	EdCIL's Overheads & Service Charges @5% on (b)	16.95
	<b>Total Expenditure</b>	<b>355.93</b> .....(c)
	Add: Service Charges @12.36% on (c)	43.99
	<b>Grand Total</b>	<b>399.92</b>

**Annexure-II**

**Detailed Budget Estimate for TSG-EdCIL & Mission Secretariat of the NMEICT for Financial Year 2014-15.**

S.No.	Description of Item	Qty. (Nos.)	Unit Cost	Total Cost (Rs. in lakhs)
<b>I) NON-RECURRING EXPENDITURE</b>				
<b>A</b>	<b>Office Expenses</b>			
1	Computer Desktops	6.00	0.50	3.00
2	Laptops [Intel Xeon 3.0 GHz 5450 Processor (server for connectivity with computers & laptops for accessing Internet & for back-up data, etc ) & Mobile Phones.	5.00	0.61	3.05
3	Hard-disk to maintain backup support	5.00	0.10	0.50
4	Modem for internet connection	2.00	0.05	0.10
5	Networking for 48 Ports / LAN Cabling, Switches, Rack other related work for Computers, Servers, etc.	1.00	2.00	2.00
6	UPS 1/5 KVA for Power Back-up for Computers & Printers, etc.	11.00	0.08	0.88
7	<b>Office Expenses</b> - Procurement of Printers			
	i) Network Printer (Heavy Duty)	6.00	0.45	2.70
	ii) Black & White Laser Jet Printer	4.00	0.25	1.00
	<b>Sub-total</b>			<b>13.23</b> .....C/o to I (A) of Appendix
<b>B.</b>	<b>Office Expenses</b> - Procurement of Softwares			
1	Server 2008, MS Office 2007 & Anti Virus 40 users, etc.	L.S.	L.S.	1.50
	<b>Sub-total</b>			<b>1.50</b> .....C/o to I (B) of Appendix
<b>C</b>	<b>Office Expenses</b> - Procurement of Office Equipment			
1	EPABX System	1.00	1.50	1.50
2	ADF Scanner [HP/Samsung]	3.00	0.40	1.20
3	Shredders	1.00	0.25	0.25
4	Fax Machine	1.00	0.50	0.50
	<b>Sub-total</b>			<b>3.45</b> .....C/o to I (C) of Appendix

S.No.	Description of Item	Qty. (Nos.)	Unit Cost	Total Cost (Rs. in lakhs)
<b>D.</b>	<b>Office Expenses</b> - Procurement of Furniture			
1	Executive Tables	2.00	0.20	0.40
2	Standard Tables	5.00	0.12	0.60
3	Executive Chairs	6.00	0.08	0.48
4	Staff Chairs	6.00	0.06	0.36
5	Visitor Chairs	2.00	0.05	0.10
6	Conference Table & Chairs	L.S.	L.S.	1.50
7	Storage Cabinet including Almirah	40	0.05	2.00
8	Heat Convector	2.00	0.02	0.04
9	Refrigerator	1.00	0.20	0.20
10	Sofa Sets & Central Table	2.00	0.25	0.50
11	Canteen Items (Crockery & Utensils)	L.S.	L.S.	0.50
12	Video Conferencing Facility	1.00	2.00	2.00
13	Carpets	L.S.	L.S.	0.50
14	Internal Furnishings including Curtains, other items as per requirement on finalization of office accommodation.	L.S.	L.S.	1.00
	<b>Sub-total</b>			<b>10.18</b>
				.....C/o to I (D) of Appendix
	<b>Total (Non-Recurring Expenditure)</b>			<b>28.36</b> ..... (I)

S.No.	Description of Item	Qty. (Nos.)	Unit Cost	Total Cost (Rs. in lakhs)
<b>II) RECURRING EXPENDITURE</b>				
<b>A.</b>	<b>Professional Services-</b> Recruitment of Consultants & Support Staff			
1	Release of Recruitment advertisement on All India basis in leading dailies.	L.S.	L.S.	1.50
2	Expert Fee/Honorarium for Resource persons for the Interview, travel expenses of the applicants & local conveyance etc.	L.S.	L.S.	1.50
3	Professional Services for Mission Secretariat- Senior Consultants/ Consultants/Junior Consultants for the Bureau, Mission Secretariat & TSG-EdCIL and Sakshat Portal Team.	-	-	124.18
4	Resource Persons			8.50
5	Studies, Feasibility Studies			5.00
	<b>Sub-total (A)</b>			<b>140.68</b> .....C/o to II (A) of Appendix
<b>B.</b>	<b>Salary &amp; Wages</b>			
	Salary & Wages Support Staff Category-I, II & III for the Bureau, Mission Secretariat.	-	-	46.24
	<b>Sub-total (B)</b>			<b>46.24</b> .....C/o to II (B) of Appendix
<b>C.</b>	<b>Over Time Allowance</b>	L.S.	L.S.	1.50
	<b>Sub-total (C)</b>			<b>1.50</b> .....C/o to II (C) of Appendix
<b>D.</b>	<b>Domestic Travel Expenses</b>			
1	Domestic Travel Expenses - Travel Expenses, Conveyance Allowance during tour, Boarding, Lodging, Resource Persons, Experts, Bureau Officials & TSG-EdCIL Official/Staff & Sakshat Portal Team for Visit / Field Visit, etc.	100	0.40	40.00
2	Local conveyance, etc. for Consultants/ Support Staff, Sakshat Portal Team & TSG-EdCIL as per applicability.	L.S.	L.S.	1.00
	<b>Sub-total (D)</b>			<b>41.00</b> .....C/o to II (D) of Appendix
<b>E.</b>	<b>Other Administrative Expenses</b>			
1	Meetings/Seminars/Workshops including venue expenses, videography/ photography, etc as per requirement.	15.00	3.00	45.00
	<b>Sub-total (F)</b>			<b>45.00</b> .....C/o to II (E) of Appendix

<b>F.</b>	<b>Publications</b>			
1	Printing of Brochures/Reports/ Newsletter/ Leaflets/Flyers & other printing jobs viz. letter heads, visiting cards& other document	L.S.	L.S.	10.00
	<b>Sub-total (F)</b>			<b>10.00</b> .....C/o to II (F) of Appendix

S.No.	Description of Item	Qty. (Nos.)	Unit Cost	Total Cost (Rs. in lakhs)
<b>G.</b>	<b>Office Expenses</b>			
1	Pantry services	L.S.	L.S.	0.50
2	Electricity & Water Charges	L.S.	L.S.	2.00
3	Mobile, Telephone, Fax & Internet charges including Data Card & DTH Connections	L.S.	L.S.	2.00
4	Office Stationery (consumables)	L.S.	L.S.	2.00
5	Postal charges	L.S.	L.S.	2.00
6	Newspaper, Magazine, CD, etc.	L.S.	L.S.	1.00
7	Photocopying & Binding charges	L.S.	L.S.	2.00
8	Legal & Audit Expenses	L.S.	L.S.	0.50
9	Vehicles for Bureau, Mission Secretariat & TSG-EdCIL for NMEICT activities (Innova/ Swift/ Indigo/ Indica, etc. – average hiring charges on monthly basis)	2.00	0.30	7.20
10	Repair & Maintenance expenses including AMC charges	L.S.	L.S.	2.00
	<b>Sub-total (G)</b>			<b>21.20</b> .....C/o to II (G) of Appendix
	<b>Total (Recurring Expenditure)</b>			<b>305.62</b> ....(II)
	<b>Total</b> [Non- recurring expenditure(Rs.28.36) + Recurring expenditure (Rs. 305.62)]			<b>333.98</b> .....(a)
	<b>Lumpsum Provisions</b> Contingency on (a) above			5.00
	<b>Total</b>			<b>338.98</b> ...(b)
	EdCIL's Overheads & Service Charges @ 5% on (b)			16.95
	<b>Total Expenditure</b>			<b>355.93</b>
	Add : Service Tax @12.36 on (c)			43.99
	<b>Grand Total</b>			<b>399.92</b>

## APPENDIX

Appendix-I	:	Minutes of the 26th Meeting of the Project Approval Board (PAB) held on 21st November, 2013
Appendix-II	:	Action Taken Report on the “Minutes of “27th Meeting of the Project Approval Board” held on 19th March, 2014
Appendix-III	:	List Universities connected by BSNL.
Appendix-IV	:	List of Universities & University Level Institutions.
Appendix-V	:	List of Centrally Funded Institutions of Jammu & Kashmir and North Eastern States.
Appendix-VI	:	Techno-Commercial Proposal Offer of BSNL.
Appendix-VII	:	Private Universities (Pending to be connected under NKN).
Appendix-VIII	:	List of New Universities Taken from UGC
Appendix-IX	:	List of Centrally Funded Institutions.
Appendix-X	:	Office Space for Mission Secretariat of NMEICT-JS(TEL) & Mission Director’s letter dated 19.05.2014.
Appendix-XI	:	Office Space for Mission Secretariat of NMEICT-DMRC Ltd’s letter No. DMRC/PD/L-1/ITP/780 dated 27.05.2014.
Appendix-XII	:	Office Space for Mission Secretariat of NMEICT-JS(TEL) & Mission Director’s letter No. F.No. 8-42/2013-TEL dated 04.06.2014.



## Appendix-I

### MINUTES OF THE 27<sup>th</sup> MEETING OF PROJECT APPROVAL BOARD OF NATIONAL MISSION ON EDUCATION THROUGH INFORMATION AND COMMUNICATION TECHNOLOGY (NMEICT) HELD ON 19<sup>th</sup> MARCH 2014 AT 11.00 A.M. AT INDIA INTERNATIONAL CENTRE (IIC) CONFERENCE ROOM (FIRST FLOOR), NEW DELHI.

The 27<sup>th</sup> Meeting of the Empowered Committee of Experts (Project Approval Board) (PAB) of National Mission on Education through Information and Communication Technology (NMEICT) was held on 19<sup>th</sup> March 2014 at 11.00 a.m. at India International Centre (IIC), Conference Room, (First Floor), New Delhi under the Chairmanship of Secretary, Department of Higher Education, Ministry of HRD.

The list of participants is at Annexure.

Joint Secretary (TEL) and Mission Director (NMEICT) & Member Secretary, PAB welcomed all the members of the re-constituted PAB. Thereafter agenda items were discussed and following decisions were reached:

#### Item No.1

##### Confirmation of the Minutes of the 26<sup>th</sup> Meeting of Project Approval Board.

Joint Secretary (TEL) and Mission Director (NMEICT) & Member Secretary, PAB, invited observations from the participants on the “Minutes of the 26th Meeting of the PAB.” Since all the members agreed and no observations on the same were received, the “Minutes of the 26th Meeting of the Project Approval Board held on 21<sup>st</sup> November, 2013” were confirmed.

#### Item No.2

##### “Action Taken Report” on the Minutes of the 26<sup>th</sup> Meeting of PAB.

Joint Secretary (TEL) and Mission Director (NMEICT) & Member Secretary reported to PAB that action has been taken and completed as per the PAB’s decision in respect of the following items:

S.No. (Agenda Item No.)	Subject/ Agenda item	Decision of PAB	Action Taken
3.1	Virtual Labs (Phase-II) by Mr. Ranjan Bose, IIT Delhi	1) Continuation of the Virtual Labs project is agreed in principle. However a small group consisting of JS&FA, JS (TEL), and PI will examine the proposal further in detail.	Separate Item (Agenda Item No 9 / Page: 42 to 45) is included on Virtual Labs (Phase-II).

S.No. (Agenda Item No.)	Subject/ Agenda item	Decision of PAB	Action Taken
		<p>2) Among other observations made by PAB, this group will examine deployment of a hub and spoke model and T2T mode - particularly for simpler experiments for much wider overreach. AICTE and UGC may be involved for making Virtual Labs as a part of the curriculum for all. Among the colleges targeted in phase II, all TEQIP colleges are to be included straightaway.</p> <p>3) The recommendations of the Group may be put up in the next PAB meeting for consideration.</p>	
3.2	E-Yantra Robot Enhanced Teaching in Engineering Colleges - Phase-II by Prof. Kavi Arya, IIT, Bombay.	PAB approved the Phase-II of E-Yantra project with an estimated cost of Rs. 1709.60 Lakhs over 3 years.	30% of Rs. 17.09 Crore has been released as first installment to the IIT, Bombay for implementation of the Project.
3.3	National Library and Information Services Infrastructure for Scholarly Content (N-LIST) by Dr. Jagdish Arora, INFLIBNET, Ahmedabad.	After detailed discussions and deliberations, it was agreed that the benefit of access to e-resources is most critical for teaching and research. Members noted that INDEST Consortium has not been able to cater to the e-resource requirements of new IITs and IISERs because of paucity of funds. As such, it was agreed that Joint Secretary (TEL) will take steps that are necessary for ensuring continuation of all N-LIST components in line with the recommendations made by the Expert Committee on Consortium constituted by the MHRD.	It has been decided that separate Budget Head for e-resources will be created in the TEL Bureau.

S.No. (Agenda Item No.)	Subject/ Agenda item	Decision of PAB	Action Taken
3.4	NMEICT Dissemination & Publicity Campaign by Mr. N. V. Reddy, DAVP.	After deliberations, PAB approved sanction of Rs.1324.8 lakhs to DAVP for 3 activities during remaining part of 2013-14 and 2014-15 with break-up as follows: i) For the assessment survey ii) For setting up hoardings at 527 Universities for 12 months iii) For using the website : Rs. 30.0 lakh : Rs. 1264.8 lakh : Rs. 30.0 lakh	30% of the project cost has been released as the first installment to DAVP.
3.5	NMEICT Dissemination and Awareness Activity through Deployment of Mobile e-learning Terminals (MeLT)- Phase:II by Dr. Vinod Kumar, IIT, Roorkee.	PAB members discussed the pros and cons of continuation of the MeLT project to Phase II. It was felt by some members that though the phase I of the project was well conceived at the time of its initiation, in the changed circumstances and rapid technological developments, putting more money into the project may not be justified. However final decision on the proposal may be based on recommendations of a committee with following members:  i) Joint Secretary (TEL) & Mission Director (NMEICT). ii) Representative of Technical Education Bureau. iii) Representative of Higher Education Bureau. iv) Representative of Central University Bureau.  The Committee will look into all aspects including assessment and usability of the present state of equipment and vans, further investment needed vis-à-vis the	It is proposed to hand over the vans to IGNOU.

S.No. (Agenda Item No.)	Subject/ Agenda item	Decision of PAB	Action Taken
		<p>proposed deployment and the exploring distribution of existing equipment to interested institutions including new IITs.</p> <p>The recommendations of the Committee may be put up before the next PAB meeting for final decision.</p>	
4	Release of Balance installments.	<p>PAB approved release of balance pending payments (in Rs. Lakhs) as follows:</p> <p>NPTEL : 365  Virtual Lab : 580  E-Yantra : 20.61  FOSSEE : 63.50  E-Kalpa : 248  E-content : 18</p> <p>generation and e-skilled test in specialized area of Information Technology  Benchmarking of : 101  ICT modules in  Physics &amp;  Chemistry</p>	Balance amount has been released to the respective projects
5	Budget Estimate for TSG-EdCIL & Mission Secretariat of NMEICT for the Financial Year 2013-14.	On the request of JS&FA, PAB resolved that issue may be examined by IFD on file. Accordingly, TEL Bureau will circulate file to IFD and take necessary approval.	Noted.
6	Amendments to the Budget Estimate of Mission Secretariat of NMEICT for the financial year 2012-13 of NMEICT.	The PAB noted the amendment in the overall value of Budget Estimates for the TSG/Mission Secretariat for financial year 2012- 13 as Rs 3.91 Crore, which was typed as Rs 3.19 Crore, erroneously, in the Minutes of 24th meeting of Project Approval Board (PAB)	Noted.  The amendment as Rs. 3.91 Crore in the overall value of the Budget Estimate for the TSG/ Mission Secretariat for

S.No. (Agenda Item No.)	Subject/ Agenda item	Decision of PAB	Action Taken
		held on 04.10.2012 and also noted the proposal to upload the said amendments to the Budget Estimate in the form of Corrigendum on Sakshat Portal along with the other Minutes of Project Approval Board (PAB).	financial year 2012-13 has been uploaded in the form of Corrigendum Sakshat Portal along with the other Minutes of Project Approval Board (PAB), since the overall value of Budget Estimate was erroneously typed as Rs 3.19 Crore in the Minutes of 24th meeting of Project Approval Board (PAB) held on 04.10.2012.
7	Other items permitted by Chair	<p>Apart from the specific agenda items listed, PAB Chairman and members also deliberated upon some common generic issues pertaining to NMEICT project as a whole, and noted the following for further action by the Mission:</p> <p>1) Chairmen of AICTE and UGC may be requested to issue an "Advisory" to all engineering colleges under their control to adopt Blending Learning mode (NMEICT e-Content + conventional content existing) to be used by their faculty. Simultaneously, discussions may be held by Mission Director with concerned stakeholders for exploring compulsory usage of NMEICT e-Contents.</p>	<p>1) Both UGC and AICTE have been addressed in this regard.</p>

S.No. (Agenda Item No.)	Subject/ Agenda item	Decision of PAB	Action Taken
		<p>2) An integrated Portal for all NMEICT content may be created for students, as presently the Sakshat Portal contains a mix of administrative information as well as e- Content, and it's difficult to navigate the Sakshat Portal by students to access e-Content and Virtual Labs, etc. JS(TEL) informed that a proposal for an Integrated e- Content Portal for NMEICT recently submitted by INFLIBNET will be presented by the PI in the next meeting of the Standing Committee.</p> <p>3) There is a need for a comprehensive review and updation of NPTEL content which was started 10 years ago, even before NMEICT project commenced.</p>	<p>2) Separate Item (Agenda Item No. 3/ Page: 13 to 22) is included on Integrated Portal.</p>

Thereafter, the said "Action Taken Report" was noted by PAB.

### Item No.3

#### **Proposal : Integrated E-Content Portal**

*Institute:* INFLIBNET

**PAB approved the project initially for One Year (Rs. 106.76 Lakhs for 2014-15) with following observations:**

- a) As per the decision of the SC meeting held on 3<sup>rd</sup> March 2014, a Policy document on e-Content creation, management and access is to be prepared by Mr Pradeep Varma, Senior Consultant (NMEICT) on issues of mapping of this integrated E-Content Portal with other NMEICT e-Content sites. This document will also include issues relating to licensing and access. The Document is to be submitted by him to next SC meeting.

- b) The Content to be delivered through upcoming DTH Channels will also be included in this Portal.
- c) After this proposal gets implemented, separate proposals can be taken up for creation of communities for different disciplines.
- d) Mr. Ajit Balakrishnan, PAB member offered to get associated with the project for enhancing and promoting usage of the Portal with effective deployment of SEO and related techniques. PI may invite him to chair the PRSG meetings for the Project.
- e) Version numbering of all Contents uploaded on Portal needs to be done.
- f) Provision for rating of various e-Content to be provided

#### **Item No.4, 5 & 6**

#### **Proposal(s): Utilisation of NMEICT Products in State Technical Universities in the Southern, Western and Northern Regions.**

*Nodal Institute: NITTTR Chennai, Bhopal and Chandigarh.*

After extensive discussions, **PAB approved the project “in principle”** with following observations:

- a) NITTTR should separately work out the cost details in two parts. First part would be the funds needed by NITTTR for Coordination and Monitoring as an extended arm of NMEICT for roll out and implementation of major NMEICT products in colleges and the second part would be for direct NITTTR budget component of training at various levels.
- b) The proposals should also carefully detail the roles of NMEICT Coordinators at various levels.
- c) The re-worked cost proposals will be presented to SC for detailed examination and recommending the exact amount to proceed further. The resolution by Chairman SC specifying the exact amount recommended will be put up in file for Chairman PAB’s approval.
- d) There is no need for coming back to PAB for these Items again.

**Item No.7****Subject :Open Licensing Policy Guidelines**

After discussions, PAB approved the Policy guidelines as proposed.

**Item No. 8****Project: Academic Incentives for Faculties involved in Blended Learning/ Technology-Enabled Learning Initiatives of NMEICT.**

As a matter of policy, the concept of Academic Incentives for adopting and using TEL initiatives was **recommended in principle by PAB**. However the members decided that this matter should be forwarded to UGC for their detailed examination and reverting back. The members desired that **“Action Taken Report” from UGC should be put up in the next PAB meeting.**

**Item No: 9****Proposal:Virtual Labs (Phase II):**

Institute: IIT Delhi

**PAB approved the project for funding of Rs. 6899.16 Lakhs** as proposed by PI with following observations:

- a) PI was advised to co-opt C-DAC as a co-PI Institution to help with the technical work of integration.
- b) For all Simulation Lab experiments constituting about 80% of total developed Labs, faster dissemination may be ensured by PI by putting them on DVDs and distribution to the Institutions.
- c) PRSG has to be re-constituted for Phase II of the Project.

**Item No. : 10****Project: ICT Mapping in Higher Education between IIT Bombay and the National University of Singapore.**

**Institute: IIT Bombay**

**PAB approved the Proposal.**



**Item No. 11**

***Proposal:* FOSSEE: Adoption of Free and Open Source Software in Education (Phase II).**

**Institute: IIT Bombay**

1. **The project was approved in principle for funding of Rs. 15.99 Crores as proposed by PI.**
2. PAB asked the PI to provide details of usage of its various sub-components as well as set targets for outreach activities to be undertaken in the project. These details are to be presented at the next Standing Committee meeting by the PI

**Item No. 12**

***Proposal:* Creation of Courseware e-content Development for remaining 58 UG Subjects at an enhanced rate of Rs.34, 000 per Module.**

**Institute: CEC & EMMRCs**

The proposal is based on the request made by the Director CEC, the recommendations of the SC in its meeting held on 6th December 2013 and the due diligence conducted by the KPMG, for development of e-content by CEC for left over 58 UG subjects (out of 87 Subjects allotted) with revised cost of Rs.34,000 per Module.

After discussions, **PAB agreed for the unit cost of Rs. 31,000 per Module** (Rs 29,000/- + Rs 2,000 as the transcription charges).

**Item No. : 13**

***Proposal :* Creating Accessible Study Material for Print Impaired Student (Main Phase).**

**Institute : Indian Institute of Technology, Kharagpur.**

The Proposal was deferred for discussion.

**Item No. 14**

***Project :* Creation of an Expert Database (VIDWAN)**

**Institute : INFLIBNET Centre, Gandhinagar.**

**PAB approved the project as proposed.**

**Item No.15****Other item discussed with the permission of Chair:**

An E-mail should be sent by UGC and AICTE for their constituent Universities and Engineering Colleges for using the connectivity provided by NMEICT to the full extent. In that mail, a short note on NMEICT available projects may be attached. Mission Director (NMEICT to take up with UGC and AICTE

The meeting ended with a Vote of Thanks to the Chair.

## ATTENDANCE SHEET

**Meeting : 27<sup>th</sup> PROJECT APPROVAL BOARD (PAB) UNDER NATIONAL MISSION ON EDUCATION THROUGH INFORMATION AND COMMUNICATION TECHNOLOGY.**

**Date/Time : 19<sup>th</sup> March, 2014 at 11.00 A.M.**

**Venue : Conference Room (First Floor), India International Centre (IIC),  
40, Max Mueller Marg, New Delhi.**

S. No.	Name, Designation & Address	Phone No., Fax & Email
1)	Secretary (HE) Ministry of Human Resource Development, Shastri Bhawan, New Delhi.	
2)	JS & FA, Ministry of Human Resource Development, Shastri Bhawan, New Delhi.	
3)	Sh. Praveen Prakash, JS (TEL) & Mission Director (NMEICT), MHRD, New Delhi	<u>Ph.</u> 011-23070770 <u>Email:</u> <a href="mailto:praveen.prakash@sakshat.ac.in">praveen.prakash@sakshat.ac.in</a>
4)	Dr. Jagdish Arora, Director, INFLIBNET Centre, Infocity, Gandhinagar-382007	Ph: 079-23268201 Mob. No.: +91-9725051200 Email: <a href="mailto:director@inflibnet.ac.in">director@inflibnet.ac.in</a> <a href="mailto:jarora@inflibnet.ac.in">jarora@inflibnet.ac.in</a> <a href="mailto:jarora42@gmail.com">jarora42@gmail.com</a> Fax: 079-23268111

**Meeting : 27<sup>th</sup> PROJECT APPROVAL BOARD (PAB) UNDER NATIONAL MISSION ON EDUCATION THROUGH INFORMATION AND COMMUNICATION TECHNOLOGY.**

**Date/Time : 19<sup>th</sup> March, 2014 at 11.00 A.M.**

**Venue : Conference Room (First Floor), India International Centre (IIC),  
40, Max Mueller Marg, New Delhi.**

<b>S. No.</b>	<b>Name, Designation &amp; Address</b>	<b>Phone No., Fax &amp; Email</b>
5)	Prof. Dr. S. Mohan Director, NITTTR, Chennai	Ph: 044-22541982 Mob. No. : +91-9444837600 Email : <a href="mailto:smohan@nitttr.ac.in">smohan@nitttr.ac.in</a> <a href="mailto:dir@nitttr.ac.in">dir@nitttr.ac.in</a>
6)	Dr. C. S. Arora Senior Consultant, NMEICT, Shastri Bhawan, New Delhi	Ph.: 01-23389093 Mob.No.: 9868259509 Email: <a href="mailto:dresarora@gmail.com">dresarora@gmail.com</a>
7)	Sh. Ajit Balakrishnan, Chairman, IIM, Calcutta	Email: <a href="mailto:ajitb@rediffmail.com">ajitb@rediffmail.com</a>
8)	Sh. Pawan Agarwal Advistor, Planning Commission, New Delhi	Ph: 011-23096631 Mob. No.: +91-981806606 Email: <a href="mailto:apawan08@gmail.com">apawan08@gmail.com</a> Fax: 011-23096631
9)	Sh. P. Anand Managing Director, Microsoft Research India	Mob.No.: 9900505309 Email : <a href="mailto:anandan@microsoft.com">anandan@microsoft.com</a>

**Meeting : 27<sup>th</sup> PROJECT APPROVAL BOARD (PAB) UNDER NATIONAL MISSION ON EDUCATION THROUGH INFORMATION AND COMMUNICATION TECHNOLOGY.**

**Date/Time : 19<sup>th</sup> March, 2014 at 11.00 A.M.**

**Venue : Conference Room (First Floor), India International Centre (IIC),  
40, Max Mueller Marg, New Delhi.**

<b>S. No.</b>	<b>Name, Designation &amp; Address</b>	<b>Phone No., Fax &amp; Email</b>
	Bangalore	
10)	Mr. Jaspal Sandhu Secretary, UGC, New Delhi	Mob.No.: +91-9501114471 Email: <a href="mailto:jssandhu@gmail.com">jssandhu@gmail.com</a>
11)	Sh. M. Balakrishnan CSE Department IIT, Delhi	Mob.No.: +91-9871666611 Email: <a href="mailto:mbala@cse.iitd.ac.in">mbala@cse.iitd.ac.in</a>
12)	Prof. H. P. Khincha Advisor, IISC Department of Elec.Engg. IISC, Bangalore.	Mob. No.: +91- 9845010476 Email: <a href="mailto:hpk1598@gmail.com">hpk1598@gmail.com</a> <a href="mailto:hpk@ee.iisc.ernet.in">hpk@ee.iisc.ernet.in</a>
13)	Prof. Kannan Moudgalya IIT, Bombay	Mob.No.: +91-9869326979 Email: <a href="mailto:kannan@iitb.ac.in">kannan@iitb.ac.in</a>
14)	Sh. Pradeep Varma, Senior Consultant, NMEICT	Mob.No.: 9818182834 Email: <a href="mailto:varma.pradeep@gmail.com">varma.pradeep@gmail.com</a> <a href="mailto:varmapradeep@gmail.com">varmapradeep@gmail.com</a>
15)	Sh. Piyush Trivedi	Mob.No.: +91 9425017913

**Meeting : 27<sup>th</sup> PROJECT APPROVAL BOARD (PAB) UNDER NATIONAL MISSION ON EDUCATION THROUGH INFORMATION AND COMMUNICATION TECHNOLOGY.**

**Date/Time : 19<sup>th</sup> March, 2014 at 11.00 A.M.**

**Venue : Conference Room (First Floor), India International Centre (IIC),  
40, Max Mueller Marg, New Delhi.**

<b>S. No.</b>	<b>Name, Designation &amp; Address</b>	<b>Phone No., Fax &amp; Email</b>
	RGPV Bhopal	
16)	Prof. D. S. Yadav Pro VC, UPTU, Lucknow.	Mob. No.: +91-9454382845
17)	Prof. M. P. Poonia Director, NITTTTR Chandigarh	Mob. No.: +91-9815575260 Email: <a href="mailto:mppoonia@gmail.com">mppoonia@gmail.com</a>
18)	Prof. Vijay Kumar Agrawal Director, NITTTTR, Bhopal	Mob.No.:+91-9425194556 Email: <a href="mailto:director@nittrbpl.ac.in">director@nittrbpl.ac.in</a>
19)	Sh. Kumar Bharat Bhushan Junior Consultant NMEICT	Mob.No.:+91-9811719601 Email: <a href="mailto:bharat.bhushan@nmeict.ac.in">bharat.bhushan@nmeict.ac.in</a>
20)	Ms. Aurobi Das Consultant NMEICT	Mob.: +91 9899265413 Email: <a href="mailto:aurobi.das@nmeict.ac.in">aurobi.das@nmeict.ac.in</a>

**Meeting : 27<sup>th</sup> PROJECT APPROVAL BOARD (PAB) UNDER NATIONAL MISSION ON EDUCATION THROUGH INFORMATION AND COMMUNICATION TECHNOLOGY.**

**Date/Time : 19<sup>th</sup> March, 2014 at 11.00 A.M.**

**Venue : Conference Room (First Floor), India International Centre (IIC),  
40, Max Mueller Marg, New Delhi.**

<b>S. No.</b>	<b>Name, Designation &amp; Address</b>	<b>Phone No., Fax &amp; Email</b>
21)	Dr. B. K. Murthy, Executive Director, CDAC, NOIDA	Ph: 0120-306300 Mob.No.:+91-9810601683 Email:
22)	Prof. Rajat Moona, Director General Pune University Campus, Pune	Ph.: 020-25696565 Mob.No.:+91-9822043911 Email: <a href="mailto:moona@cdac.ac.in">moona@cdac.ac.in</a>
23)	Prof. S.V. Raghavan Scientific Secretary	Ph: 23022115
24)	Prof. M. S. Ananth Visiting Professor, IISc Bangalore, (Former Director, IIT Madras)	Ph: 22933114 Mob.No.:+91-9008020793 Email: <a href="mailto:ananth@iitm.ac.in">ananth@iitm.ac.in</a>
25)	Prof. D.B. Phatak Prof. CSE IIT, Bombay, Mumbai-400076	Ph.: 25767747 Mob.: +91 9820017052 Email : <a href="mailto:dbp@it.iitb.ac.in">dbp@it.iitb.ac.in</a>

**Meeting : 27<sup>th</sup> PROJECT APPROVAL BOARD (PAB) UNDER NATIONAL MISSION ON EDUCATION THROUGH INFORMATION AND COMMUNICATION TECHNOLOGY.**

**Date/Time : 19<sup>th</sup> March, 2014 at 11.00 A.M.**

**Venue : Conference Room (First Floor), India International Centre (IIC),  
40, Max Mueller Marg, New Delhi.**

<b>S. No.</b>	<b>Name, Designation &amp; Address</b>	<b>Phone No., Fax &amp; Email</b>
26)	Sh. S.S. Mantha, Chairman, AICTE	Mob.No.:+91-9958881066 Email: <a href="mailto:ssmantha@vjti.org.in">ssmantha@vjti.org.in</a>
27)	Sh. Y. Raghu Reddy, Associate Professor, IIIT, Hyderabad (Vlab Project)	Mob.No.:+91-9849371681 Email: <a href="mailto:Raghu.reddy@iiit.ac.in">Raghu.reddy@iiit.ac.in</a>
28)	Prof. Ranjan Bose Professor, IIT, Delhi	Mob.No.:+91-9818253072 Email: <a href="mailto:rbose.iitd@gmail.com">rbose.iitd@gmail.com</a>
29)	Dr. Suresh Bhalla, Associate Professor, IIT, Delhi	Ph: 2659 1040 Mob.No.:+91-9810722691 Email: <a href="mailto:sbhalla@civil.iitd.ac.in">sbhalla@civil.iitd.ac.in</a>
30)	Sh. Vankatesh Choppella Associate Professor, IIIT, Hyderabad	Mob.No.:+91-9652740281 Email: <a href="mailto:vankatesh.choppella@iiit.ac.in">vankatesh.choppella@iiit.ac.in</a>
31)	Sh. A. U. Digraskar CPA,	Mob.No.:+91-9910493290 Email: <a href="mailto:aud233@gmail.com">aud233@gmail.com</a>



**Meeting : 27<sup>th</sup> PROJECT APPROVAL BOARD (PAB) UNDER NATIONAL MISSION ON EDUCATION THROUGH INFORMATION AND COMMUNICATION TECHNOLOGY.**

**Date/Time : 19<sup>th</sup> March, 2014 at 11.00 A.M.**

**Venue : Conference Room (First Floor), India International Centre (IIC),  
40, Max Mueller Marg, New Delhi.**

<b>S. No.</b>	<b>Name, Designation &amp; Address</b>	<b>Phone No., Fax &amp; Email</b>
	NPIU, EdCIL House, Plot No. 18A, Sector 16A NOIDA	
32)	Sh. Pradeep Kaul Senior Consultant NMEICT, MHRD 121 A, C-Wing, Shastri Bhawan, New Delhi	Mob.No.:+91-9868274690 Email: <a href="mailto:kaulp@rediffmail.com">kaulp@rediffmail.com</a> <a href="mailto:kaulp428@gmail.com">kaulp428@gmail.com</a>
33)	Mr. Sachi Ghai Consultant, KPMG 8 <sup>th</sup> Floor, Building IOC, DLF Cybercity	Mob:+91-9818024157 Email: <a href="mailto:sachighai@kpmg.com">sachighai@kpmg.com</a>
34)	Sh. Ashutosh Mahajan Asstt. Professor, IIT, Bombay, Powai, Mumbai-400 076	Mob.No.:+91- 9819809418 Email: <a href="mailto:amahajan@iitb.ac.in">amahajan@iitb.ac.in</a>
35)	Sh. Jayendran Asstt. Professor,	Mob.No.:+91-9969153249 Email: <a href="mailto:jayendran@iitb.ac.in">jayendran@iitb.ac.in</a>

**Meeting : 27<sup>th</sup> PROJECT APPROVAL BOARD (PAB) UNDER NATIONAL MISSION ON EDUCATION THROUGH INFORMATION AND COMMUNICATION TECHNOLOGY.**

**Date/Time : 19<sup>th</sup> March, 2014 at 11.00 A.M.**

**Venue : Conference Room (First Floor), India International Centre (IIC),  
40, Max Mueller Marg, New Delhi.**

<b>S. No.</b>	<b>Name, Designation &amp; Address</b>	<b>Phone No., Fax &amp; Email</b>
	IIT, Bombay, Powai, Mumbai-400 076	
36)	Sh. Sanjeet Kumar Project Staff Bharti School of Telecom Tech & Management IIT, Delhi	Mob.No.:+91-9891262758 Email: <a href="mailto:sanjeetkumar.iitd@gmail.com">sanjeetkumar.iitd@gmail.com</a>
37)	Shri A.K. Singh Director (ICT) & Nodal Officer (NMEICT) MHRD, Shastri Bhawan, New Delhi	Ph: 011-23384276 Mob.No.: +91 9968720084 Email: <a href="mailto:anandksingh.edu@nic.in">anandksingh.edu@nic.in</a> <a href="mailto:a.k.singh@bsnl.co.in">a.k.singh@bsnl.co.in</a>
38)	Sh. Sameer Jain Lead, Government Advisory KPMG, New Delhi	Mob.No.:+91-8130791158 Email: <a href="mailto:sameerjain@kpmg.com">sameerjain@kpmg.com</a>
39)	Mr. Sanjay Agrawal Dean R & D NITTTR, Bhopal	Mob.No.:+91-09425004434 Email: <a href="mailto:ragrawal@nitttrbpl.ac.in">ragrawal@nitttrbpl.ac.in</a>
40)	Sh. Abhishek Kumar	Ph: 079-2326 8280

**Meeting : 27<sup>th</sup> PROJECT APPROVAL BOARD (PAB) UNDER NATIONAL MISSION ON EDUCATION THROUGH INFORMATION AND COMMUNICATION TECHNOLOGY.**

**Date/Time : 19<sup>th</sup> March, 2014 at 11.00 A.M.**

**Venue : Conference Room (First Floor), India International Centre (IIC),  
40, Max Mueller Marg, New Delhi.**

<b>S. No.</b>	<b>Name, Designation &amp; Address</b>	<b>Phone No., Fax &amp; Email</b>
	Scientist (CS) INFLIBNET Centre, Gandhinagar	Mob.No.:+91-9725639307 Email: <a href="mailto:abhishek@inflibnet.ac.in">abhishek@inflibnet.ac.in</a>
41)	Sh. Mithun Dutta Senapati, System Administrator Shastri Bhawan, New Delhi	Mob.No.:+91-9810647042 Email: <a href="mailto:mithun@nmeict.ac.in">mithun@nmeict.ac.in</a>
42)	Sh. Nageshwar Nath, ME, CEC, IUAC, New Delhi	Mob.No.:+91-9871413322 Email: <a href="mailto:director.cec@nic.in">director.cec@nic.in</a>
43)	Prof. Rajbir singh Director, CEC	Mob.No.:+91- Email:
44)	Prof. S. Dhanapal Professor, CDC, NITTTR, Chennai	Ph: 044-2254 5442 Mob.No.:+91-9841956985 Email: <a href="mailto:rasdp53@gmail.com">rasdp53@gmail.com</a>
45)	Dr. G. Janardhanan	Ph: 044 2254 5460

**Meeting : 27<sup>th</sup> PROJECT APPROVAL BOARD (PAB) UNDER NATIONAL MISSION ON EDUCATION THROUGH INFORMATION AND COMMUNICATION TECHNOLOGY.**

**Date/Time : 19<sup>th</sup> March, 2014 at 11.00 A.M.**

**Venue : Conference Room (First Floor), India International Centre (IIC),  
40, Max Mueller Marg, New Delhi.**

<b>S. No.</b>	<b>Name, Designation &amp; Address</b>	<b>Phone No., Fax &amp; Email</b>
	Associate Professor, Head I/C CEM, NITTTR Chennai-113	Mob.No.:+91- 944520968 Email: <a href="mailto:jana@nittr.ac.in">jana@nittr.ac.in</a>
46)	Sh. R. P. Agrawal Former Secretary (HE)	Mob.No.:+91- 991082331 Email: <a href="mailto:rpa1949@gmail.com">rpa1949@gmail.com</a>
47)	Sh. Vaibhav Agarwal Software Engineer, Sakshat Portal Team, NMEICT	Mob.No.:+91-9899770836 Email: <a href="mailto:vaibhav@sakshat.ac.in">vaibhav@sakshat.ac.in</a>

## ACTION TAKEN REPORT

ON THE MINUTES OF 27<sup>th</sup> MEETING OF PROJECT APPROVAL BOARD (PAB) OF NATIONAL MISSION ON EDUCATION THROUGH INFORMATION AND COMMUNICATION TECHNOLOGY (NMEICT) HELD ON 19<sup>th</sup> March, 2014.

Item	Action Taken
<p><b>Item No.3</b></p> <p><b>Approval of New Proposals:</b></p> <p><b>Proposal : Integrated E-Content Portal</b>  <i>Institute: INFLIBNET</i></p> <p><b>PAB approved the project initially for One Year (Rs. 106.76 Lakhs for 2014-15) with following observations:</b></p> <ul style="list-style-type: none"> <li>a) As per the decision of the SC meeting held on 3<sup>rd</sup> March 2014, a Policy document on e-Content creation, management and access is to be prepared by Mr. Pradeep Varma, Senior Consultant (NMEICT) on issues of mapping of this integrated E-Content Portal with other NMEICT e-Content sites. This document will also include issues relating to licensing and access. The Document is to be submitted by him to next SC meeting.</li> <li>b) The Content to be delivered through upcoming DTH Channels will also be included in this Portal.</li> <li>c) After this proposal gets implemented, separate proposals can be taken up for creation of communities for different disciplines.</li> <li>d) Mr. Ajit Balakrishnan, PAB member offered to get associated with the project for enhancing and promoting usage of the Portal with effective deployment of SEO and related techniques. PI may invite him to chair the PRSG meetings for the Project.</li> <li>e) Version numbering of all Contents uploaded on Portal needs to be done.</li> <li>f) Provision for rating of various e-Content to be provided.</li> </ul>	<p><b>1<sup>st</sup> installment of Rs. 32.00 lakhs has been released to INFLIBNET, Ahmedabad.</b></p>

Item	Action Taken
<p><b>Item No.4, 5 &amp; 6</b></p> <p><b>Proposal(s): Utilization of NMEICT Products in State Technical Universities in the Southern, Western and Northern Regions.</b></p> <p><i>Nodal Institute: NITTTR Chennai, Bhopal and Chandigarh.</i></p> <p>After extensive discussions, <b>PAB approved the project “in principle”</b> with following observations:</p> <p>a) NITTTR should separately work out the cost details in two parts. First part would be the funds needed by NITTTR for Coordination and Monitoring as an extended arm of NMEICT for roll out and implementation of major NMEICT products in colleges and the second part would be for direct NITTTR budget component of training at various levels.</p> <p>b) The proposals should also carefully detail the roles of NMEICT Coordinators at various levels.</p> <p>c) The re-worked cost proposals will be presented to SC for detailed examination and recommending the exact amount to proceed further. The resolution by Chairman SC specifying the exact amount recommended will be put up in file for Chairman PAB’s approval.</p> <p>d) There is no need for coming back to PAB for these Items again.</p>	<p>Standing Committee has authorized standing committee Chairman to take decision in this regard.</p>
<p><b>Item No.7</b></p> <p><b>Subject :Open Licensing Policy Guidelines</b></p> <p>After discussions, PAB approved the Policy guidelines as proposed.</p>	<p>Workshop with stakeholders was conducted to popularize the decision.</p>
<p><b>Item No. 8</b></p> <p><b>Project: Academic Incentives for Faculties involved in Blended Learning/ Technology-Enabled Learning Initiatives of NMEICT.</b></p> <p>As a matter of policy, the concept of Academic Incentives for adopting and using TEL initiatives was <b>recommended in principle by PAB</b>. However the members decided that this matter should be forwarded to UGC for their detailed examination and reverting back. The members desired that <b>“Action Taken Report” from UGC should be put up in the next PAB meeting.</b></p>	<p>Will follow up with UGC</p>

Item	Action Taken
<p><b>Item No: 9</b></p> <p><b>Proposal: Virtual Labs (Phase II):</b> Institute: IIT Delhi</p> <p><b>PAB approved the project for funding of Rs. 6899.16 Lakhs</b> as proposed by PI with following observations:</p> <ul style="list-style-type: none"> <li>a) PI was advised to co-opt C-DAC as a co-PI Institution to help with the technical work of integration.</li> <li>b) For all Simulation Lab experiments constituting about 80% of total developed Labs, faster dissemination may be ensured by PI by putting them on DVDs and distribution to the Institutions.</li> <li>c) PRSG has to be re-constituted for Phase II of the Project.</li> </ul>	<p><b>1<sup>st</sup> installment of Rs. 14.15 Cr. for Virtual Lab Ph II has been released to IIT Delhi.</b></p>
<p><b>Item No. : 10</b></p> <p><b>Project: ICT Mapping in Higher Education between IIT Bombay and the National University of Singapore.</b></p> <p><b>Institute: IIT Bombay</b></p> <p><b>PAB approved the Proposal.</b></p>	<p><b>1<sup>st</sup> installment of Rs. 15.93 lakhs has been released to IIT Bombay.</b></p>
<p><b>Item No. 11</b></p> <p><b>Proposal: FOSSEE: Adoption of Free and Open Source Software in Education (Phase II).</b></p> <p><b>Institute: IIT Bombay</b></p> <ul style="list-style-type: none"> <li>1. <b>The project was approved in principle for funding of Rs. 15.99 Crores</b> as proposed by PI.</li> <li>2. PAB asked the PI to provide details of usage of its various sub-components as well as set targets for outreach activities to be undertaken in the project. These details are to be presented at the next Standing Committee meeting by the PI.</li> </ul>	<p><b>1<sup>st</sup> installment of Rs. 4.45 Cr. has been released to IIT Bombay.</b></p>

Item	Action Taken
<p><b>Item No. 12</b></p> <p><b>Proposal:</b> Creation of Courseware e-content Development for remaining 58 UG Subjects at an enhanced rate of Rs.34, 000 per Module.</p> <p><b>Institute:</b> CEC &amp; EMMRCs</p> <p>The proposal is based on the request made by the Director CEC, the recommendations of the SC in its meeting held on 6th December 2013 and the due diligence conducted by the KPMG, for development of e-content by CEC for left over 58 UG subjects (out of 87 Subjects allotted) with revised cost of Rs.34,000 per Module.</p> <p>After discussions, <b>PAB agreed for the unit cost of Rs. 31,000 per Module</b> (Rs 29,000/- + Rs 2,000 as the transcription charges).</p>	<p><b>Rs. 17.80 crore has been released to CEC</b></p>
<p><b>Item No. : 13</b></p> <p><b>Proposal :</b> Creating Accessible Study Material for Print Impaired Student (Main Phase).</p> <p><b>Institute:</b> Indian Institute of Technology, Kharagpur.</p> <p>The Proposal was deferred for discussion.</p>	
<p><b>Item No. 14</b></p> <p><b>Project :</b> Creation of an Expert Database (VIDWAN)</p> <p><b>Institute:</b> INFLIBNET Centre, Gandhinagar.</p> <p><b>PAB approved the project as proposed.</b></p>	<p><b>1<sup>st</sup> installment of Rs. 15.81 lakhs has been released to INFLIBNET, Ahmedabad.</b></p>
<p><b>Item No.15</b></p> <p><b>Other item discussed with the permission of Chair:</b></p> <p>An E-mail should be sent by UGC and AICTE for their constituent Universities and Engineering Colleges for using the connectivity provided by NMEICT to the full extent. In that mail, a short note on NMEICT available projects may be attached. Mission Director (NMEICT to take up with UGC and AICTE.</p>	<p>NMEICT brochure has been shared with Chairman AICTE and Chairman UGC for further transmission to the colleges and universities.</p>



## Appendix-III

### NMEICT OVERALL STATUS AS ON 31st May, 2014

S.No	Name of University	Name of Circle	Govt / Pvt	Status	Date of Provisioning
1	Acharya Nagarjuna University, Nagarjuna Nagar, Guntur-522510.	Adnhra Pradesh	Govt.	Commissioned	01-01-2020
2	Andhra University, Vishakhapatnam-530003.	Adnhra Pradesh	Govt.	Commissioned	01-01-2020
3	Gandhi Institute of Technology and management (GITAM), Gandhi Nagar Campus, Rushikonda, Visakhapatnam-530045.	Adnhra Pradesh	Pvt.	Commissioned	01-01-2020
4	Jawaharlal Nehru Technological University, Kakinada,	Adnhra Pradesh	Govt.	Commissioned	01-01-2020
5	Kakatiya University, Warangal-506009.	Adnhra Pradesh	Govt.	Commissioned	01-01-2020
6	Koneru Lakshmaiah Education Foundation, Greengields, Kunchabnapli Post, Vaddeswaram, Guntur District, Andhra Pradesh	Adnhra Pradesh	Pvt.	Commissioned	01-01-2020
7	Rashtriya Sanskrity Vidyapeeth, Tirupati-517507.	Adnhra Pradesh	Govt.	Commissioned	01-01-2020
8	Sri Padmavati Mahila Vishwavidyalayam, Triupati-517507.	Adnhra Pradesh	Govt.	Commissioned	01-01-2020
9	Sri Venkateswara University, Tirpuati-517507.	Adnhra Pradesh	Govt.	Commissioned	01-01-2020
10	Telangana University, Nizamabad	Adnhra Pradesh	Govt.	Commissioned	01-01-2020
11	Vignan's Foundation for Science, Technology and Research, Vadlmaudi, Guntur District, Andhra Pradesh.	Adnhra Pradesh	Pvt.	Commissioned	01-01-2020
12	Yogi Vemana University, Vemanapuram, Kadapa-516003	Adnhra Pradesh	Govt.	Commissioned	01-01-2020

<b>S.No</b>	<b>Name of University</b>	<b>Name of Circle</b>	<b>Govt / Pvt</b>	<b>Status</b>	<b>Date of Provisioning</b>
13	NIT Warangal	Adnhra Pradesh	Govt.	Commissioned	01-01-2020
14	Rajiv Gandhi University of Knowledge Technologies, Idupulapaya, Kadapa	Adnhra Pradesh	Govt.	Commissioned	01-01-2020
15	Andhra Pradesh University of Health Sciences, Vijayawada-520008.	Adnhra Pradesh	Govt.	Commissioned	01-01-2020
16	Dravidian University, Kuppam-517425.	Adnhra Pradesh	Govt.	Commissioned	01-01-2020
17	Jawaharlal Nehru Technological University, Anantpur	Adnhra Pradesh	Govt.	Commissioned	01-01-2020
18	Mahatma Gandhi University, Panagal, Nalgonda-500803	Adnhra Pradesh	Govt.	Commissioned	01-01-2020
19	Sri Krishnadevaraya University, Anantapur - 515003.	Adnhra Pradesh	Govt.	Commissioned	01-01-2020
20	Sri Sathya Sai Institute of Higher Learning, Prasanthinilayam, Anantapur-515134.	Adnhra Pradesh	Pvt.	Commissioned	01-01-2020
21	Maulana Azad National Urdu University, Hyderabad-500803.	Adnhra Pradesh	Govt.	Commissioned	01-01-2020
22	Osmania University, Hyderabad-500007.	Adnhra Pradesh	Govt.	Commissioned	01-01-2020
23	The English and Foreign Languages University, Hyderabad-500007.	Adnhra Pradesh	Govt.	Commissioned	01-01-2020
24	International Institute of Information Technology, Hyderabad-500072.	Adnhra Pradesh	Govt.	Commissioned	01-01-2020
25	Dr. B.R. Ambedkar Open University, Jubilee Hills, Hyderabad-500033.	Adnhra Pradesh	Govt.	Commissioned	01-01-2020
26	Jawaharlal Nehru Technological University, Hyderabad-500072.	Adnhra Pradesh	Govt.	Commissioned	01-01-2020

<b>S.No</b>	<b>Name of University</b>	<b>Name of Circle</b>	<b>Govt / Pvt</b>	<b>Status</b>	<b>Date of Provisioning</b>
27	National Academy of Legal Studies & Research University, Hyderabad-500027.	Adnhra Pradesh	Govt.	Commissioned	01-01-2020
28	Potti Sreeramulu Telugu University, Hyderabad-500004.	Adnhra Pradesh	Govt.	Commissioned	01-01-2020
29	Vikram Simhapuri University, Nellore	Adnhra Pradesh	Govt.	Commissioned	01-01-2020
30	Krishna University, Machilipatnam	Adnhra Pradesh	Govt.	Commissioned	01-01-2020
31	School of Planning and Architecture, Vijayawada	Adnhra Pradesh	Govt.	Commissioned	01-01-2020
32	Assam University, Silchar-788011	Assam	Govt.	Commissioned	01-01-2020
33	Krishna Kanta Handique State Open University, Last Gate Dispur, Guwahati – 781006.	Assam	Govt.	Commissioned	01-01-2020
34	Dibrugrah University, Dibrugrah-78004	Assam	Govt.	Commissioned	01-01-2020
35	Gauhati University, Guwahati-781014	Assam	Govt.	Commissioned	01-01-2020
36	Tezpur University, Tezpur-784028	Assam	Govt.	Commissioned	01-01-2020
37	NIT Silchar	Assam	Govt.	Commissioned	01-01-2020
38	Don Basko University	Assam	Govt.	Commissioned	01-01-2020
39	Patna University, Patna-800005	Bihar	Govt.	Commissioned	01-01-2020
40	Nalanda Open University, Patna-800001 *	Bihar	Govt.	Commissioned	01-01-2020
41	Babasahe Bhimrao Ambedkar Bihar University, Muzaffarpur-842001	Bihar	Govt.	Commissioned	01-01-2020
42	Bhupendra Narayan Mandal University, Madhepura-852113	Bihar	Govt.	Commissioned	01-01-2020

S.No	Name of University	Name of Circle	Govt / Pvt	Status	Date of Provisioning
43	Chanakya National Law University, A.N. Sinha Institute of Social Studies Campus, Gandhi Maidan, Patna-800001	Bihar	Govt.	Commissioned	01-01-2020
44	Central University of Bihar, Phaneeshwarnath Renu, Hindi Bhawan, Chhajjubagh, Patna-1,	Bihar	Govt.	Commissioned	01-01-2020
45	Jai Prakash University, Chhapra-8410301.	Bihar	Govt.	Commissioned	01-01-2020
46	K.S. Darbhanag Sanskrit Vishwavidyalaya, Darbhanga-846008	Bihar	Govt.	Commissioned	01-01-2020
47	Lalit Narayan Mithila University, Darbhanga-846008	Bihar	Govt.	Commissioned	01-01-2020
48	MagadhUniversity, Bodh Gaya-824234	Bihar	Govt.	Commissioned	01-01-2020
49	Maulana Mazharul Haque Arabic & Persian University, 3 Polo Road, Patna-800001	Bihar	Govt.	Commissioned	01-01-2020
50	Rajendra Agricultural University, Samastipur	Bihar	Govt.	Commissioned	01-01-2020
51	T.M. University, Bhagalpur-812007	Bihar	Govt.	Commissioned	01-01-2020
52	Veer Kunwar Singh University, Arrah-802301.	Bihar	Govt.	Commissioned	01-01-2020
53	Chhattisgarh Swami vivekanand Technical University, Bilai	Chattisgarh	Govt.	Commissioned	01-01-2020
54	Guru Ghasidas Vishwavidyalaya, Bilaspur-495009	Chattisgarh	Govt.	Commissioned	01-01-2020
55	Hidayatullah National Law University, Civil Lines, Raipur-492001.	Chattisgarh	Govt.	Commissioned	01-01-2020
56	Kushabhau Thakre Patrakarita Avam Jansanchar Vishwavidyalaya, Raipur	Chattisgarh	Govt.	Commissioned	01-01-2020

S.No	Name of University	Name of Circle	Govt / Pvt	Status	Date of Provisioning
57	Pt. Ravishankar Shukla University, Raipur-492010	Chattisgarh	Govt.	Commissioned	01-01-2020
58	Indian Institute of Management - Raipur	Chattisgarh	Govt.	Commissioned	01-01-2020
59	Bhavnagar University, Bhavnagar-364002	Gujarat	Govt.	Commissioned	01-01-2020
60	Central University, of Gujarat, Plot No. 95/1, Sector2A, Gandhinagar-3820007	Gujarat	Govt.	Commissioned	01-01-2020
61	Dr. Babasaheb Ambedkar Open University, Ahmedabad-380003	Gujarat	Govt.	Commissioned	01-01-2020
62	Gujarat Agricultural university, Sardar Krushinagar, Danthiwada, Banaskantha-385506	Gujarat	Govt.	Commissioned	01-01-2020
63	Gujarat Ayurveda University, Jamnagar-361008.	Gujarat	Govt.	Commissioned	01-01-2020
64	Gujarat National Law University, E-4 GIDC, Electronics, Gandhinagar-382028.	Gujarat	Govt.	Commissioned	01-01-2020
65	Gujarat University, Ahmedabad-380009	Gujarat	Govt.	Commissioned	01-01-2020
66	Hemchandraacharya North Gujarat University, P.B. No. 21, University Road, Patan-384265	Gujarat	Govt.	Commissioned	01-01-2020
67	Krantiguru shyamji Krishna Verma Kachchh University, CS-60, Jubilee Ground, Bhuj-Kachchh-370001.*	Gujarat	Govt.	Commissioned	01-01-2020
68	Maharaja Sayajirao University of Baroda, Vadodara-390002	Gujarat	Govt.	Commissioned	01-01-2020
69	Sardar Patel University, Vallabh Vidhanagar-388120	Gujarat	Govt.	Commissioned	01-01-2020
70	Saurashtra University, Rajkot-360005	Gujarat	Govt.	Commissioned	01-01-2020

S.No	Name of University	Name of Circle	Govt / Pvt	Status	Date of Provisioning
71	Veer Narmad South Gujarat University, Surat-395007,	Gujarat	Govt.	Commissioned	01-01-2020
72	NIT Surat	Gujarat	Govt.	Commissioned	01-01-2020
73	Centre for Environmental Planning and Technology University, University Road, Narvrangpura Ahemdabad-380009	Gujarat	Govt.	Commissioned	01-01-2020
74	Dhirubhai Ambani Institute of Information and communication Technology, Gandhinagar, Post Box No.4, Gandhinagar-382007	Gujarat	Pvt.	Commissioned	01-01-2020
75	Ganpat University, Ganpat Vidyanagar, Mehsana, goazaria Highway, District Mehsana-380711	Gujarat	Pvt.	Commissioned	01-01-2020
76	Gujarat Technological University, JACPC Building, L.D.College of Engineering Campus, Navrangpura, Ahmedabad	Gujarat	Govt.	Commissioned	01-01-2020
77	Gujarat vidhyapeeth, PO Navjivan, Ashram Road, Ahmedabad-380014	Gujarat	Pvt.	Commissioned	01-01-2020
78	Kadi Sarva Vishwavidyalaya, Srva Vidyalayam, CS-60, Jubilee Ground, Bhuj-Kachchh-370001.*	Gujarat	Govt.	Commissioned	01-01-2020
79	Pandit Deendayal Petroleum University, At Raisan, Dist Gandhinagar-382009	Gujarat	Pvt.	Commissioned	01-01-2020
80	Shree Somnath Sanskrit University, Ta: Veraval, District Junagarh-360068	Gujarat	Govt.	Commissioned	01-01-2020

<b>S.No</b>	<b>Name of University</b>	<b>Name of Circle</b>	<b>Govt / Pvt</b>	<b>Status</b>	<b>Date of Provisioning</b>
81	Sumandeep Vidyapeeth, village Piparia, Taluka Waghodia, District Vadodara	Gujarat	Pvt.	Commissioned	01-01-2020
82	Kurukshetra University, Kurukshetra-136119	Haryana	Govt.	Commissioned	01-01-2020
83	Maharishi Dayanand University, Rohtak-124001	Haryana	Govt.	Commissioned	01-01-2020
84	Pt.Bhagawath Dayal Sharma University of Health Sciences,Rohtak	Haryana	Govt.	Commissioned	01-01-2020
85	Bhagat Phool Singh Mahila vishywavidyalya, Khanpur Kalan Sonipat	Haryana	Govt.	Commissioned	01-01-2020
86	Central university of Haryana,Gurgaon	Haryana	Govt.	Commissioned	01-01-2020
87	Chaudhary Devi Lal University, Sirsa.	Haryana	Govt.	Commissioned	01-01-2020
88	Deen Bandhu chhotu Ram University of Science & Technology, Murtha	Haryana	Govt.	Commissioned	01-01-2020
89	Guru Jambeshwar University of Science and Technology, Hisar-125001	Haryana	Govt.	Commissioned	01-01-2020
90	Maharishi Markandeshwar Education Trust,55, Model Town, Ambala city-134003	Haryana	Pvt.	Commissioned	01-01-2020
91	Lingayas University, Old Faridabad	Haryana	Pvt.	Commissioned	01-01-2020
92	Amity University, Manesar (Haryana)	Haryana	Pvt.	Commissioned	01-01-2020
93	Central University of Himachal Pradesh	Himanchal Pradesh	Govt.	Commissioned	01-01-2020
94	Chitkara University, HIMUDA Education Hub, Kallujhanda(Barotiwala), Distt. Solan-174103	Himanchal Pradesh	Pvt.	Commissioned	01-01-2020

S.No	Name of University	Name of Circle	Govt / Pvt	Status	Date of Provisioning
95	Himachal Pradesh University, Shimla-171005	Himanchal Pradesh	Govt.	Commissioned	01-01-2020
96	J.P. UNIVERSITY, WAKNAGHAT, SOLAN	Himanchal Pradesh	Pvt.	Commissioned	01-01-2020
97	Shri Mata Vaishno Devi University, Kakrayal P.O. Kakryal, Sist. Udampur, Jammu	Jammu & Kashmir	Govt.	Commissioned	01-01-2020
98	Baba Ghulam Shah Badshah University, Rajouri Camp office, Bypass Road, Opp. Chennai Himmat, Jammu *.	Jammu & Kashmir	Govt.	Commissioned	01-01-2020
99	Central of University of Jammu & Kashmir, Qureshi Manzil, 50-Naseemabad, Saderbal, Srinagar -190006	Jammu & Kashmir	Govt.	Commissioned	01-01-2020
100	Islamic University of Science & Technology University, awantipora, Pulwama	Jammu & Kashmir	Govt.	Commissioned	01-01-2020
101	Kashmir University, Srinagar-190006	Jammu & Kashmir	Govt.	Commissioned	01-01-2020
102	Sher-e-Kashmir University of Agricultural Science & Technology, Srinagar-191121	Jammu & Kashmir	Govt.	Commissioned	01-01-2020
103	NIT Srinagar	Jammu & Kashmir	Govt.	Commissioned	01-01-2020
104	Central University of Jammu	Jammu & Kashmir	Govt.	Commissioned	01-01-2020
105	Central University of Jharkand, State Guest House, Ranchi-9, Jharkhand	Jharkhand	Govt.	Commissioned	01-01-2020
106	Indian School of Mines, Dhanbad-826004.	Jharkhand	Govt.	Commissioned	01-01-2020
107	Vinoba Bhave University, Hazaribagh-825301	Jharkhand	Govt.	Commissioned	01-01-2020



S.No	Name of University	Name of Circle	Govt / Pvt	Status	Date of Provisioning
108	Birla Institute of Technology, Mesra, Ranchi-835215.	Jharkhand	Pvt.	Commissioned	01-01-2020
109	Kolhan University, Chaibasa	Jharkhand	Govt.	Commissioned	01-01-2020
110	Sido Kanhu Murmu University, Dumka-814101	Jharkhand	Govt.	Commissioned	01-01-2020
111	Ranchi University, Ranchi-834001	Jharkhand	Govt.	Commissioned	01-01-2020
112	NIT Jamshedpur	Jharkhand	Govt.	Commissioned	01-01-2020
113	Nilamaber Pitamber University	Jharkhand	Govt.	Commissioned	01-01-2020
114	Central University of Karnataka, 2 <sup>nd</sup> Floor, Karya Saudha, Gulbarga University, Gulbarga-585106 Karnataka	Karnataka	Govt.	Commissioned	01-01-2020
115	Gulbarga University, Gulbarga-585106	Karnataka	Govt.	Commissioned	01-01-2020
116	Karnataka University , Dharwad-580003	Karnataka	Govt.	Commissioned	01-01-2020
117	Kannada University, Hampi, Bellary District, Kamalapura-583276	Karnataka	Govt.	Commissioned	01-01-2020
118	Kuvempu University, Shankaraghatta-577451	Karnataka	Govt.	Commissioned	01-01-2020
119	Mangalore University, Mangalore-574199	Karnataka	Govt.	Commissioned	01-01-2020
120	Mysore University, Mysore-570005	Karnataka	Govt.	Commissioned	01-01-2020
121	NITTE University, Mangalore575003, Karnataka.	Karnataka	Pvt.	Commissioned	01-01-2020
122	Tumkur University, 1st Floor, Dr B.R. Ambedkar Bhawan, M.G. Road, Tumkur-572101	Karnataka	Govt.	Commissioned	01-01-2020
123	University of Agricultural Sciences, Dharwad	Karnataka	Govt.	Commissioned	01-01-2020

<b>S.No</b>	<b>Name of University</b>	<b>Name of Circle</b>	<b>Govt / Pvt</b>	<b>Status</b>	<b>Date of Provisioning</b>
124	Visveswaraiah Technological University, Belgaum-590010	Karnataka	Govt.	Commissioned	01-01-2020
125	Yenepoya University, Mangalore, Karnataka	Karnataka	Pvt.	Commissioned	01-01-2020
126	NIT Surathkal	Karnataka	Govt.	Commissioned	01-01-2020
127	Karnataka State Open University, Mysore-570006	Karnataka	Govt.	Commissioned	01-01-2020
128	Karnataka State Women University, Bijapur-580003	Karnataka	Govt.	Commissioned	01-01-2020
129	Karnataka Veterinary, Animal & Fisheries Science University, Nandinagar, PB No. 6, Bidar-585401	Karnataka	Govt.	Commissioned	01-01-2020
130	Manipal Academy of Higher Education, Manipal -576104.	Karnataka	Pvt.	Commissioned	01-01-2020
131	Sri Devraj Urs Academy of Higher Education and Research, Tamaka, Kolar	Karnataka	Pvt.	Commissioned	01-01-2020
132	Karnataka Sate Law University, Hubli	Karnataka	Govt.	Commissioned	01-01-2020
133	KLE Academy of Higher Education and Research, Belgaum	Karnataka	Govt.	Commissioned	01-01-2020
134	Davangere University, Davangere	Karnataka	Govt.	Commissioned	01-01-2020
135	Bangalore University, Bangalore-560056	BGTD	Govt.	Commissioned	01-01-2020
136	Jain University, 91/2, Dr. A. N. Krishna Rao Road, V.V. Puram, Bangalore	BGTD	Pvt.	Commissioned	01-01-2020
137	International Institute of Information Technology, 26/c, Opp.Infosys (Gate-1), Electronic City, Hosur Road, Bangalore, 560100	BGTD	Govt.	Commissioned	01-01-2020

S.No	Name of University	Name of Circle	Govt / Pvt	Status	Date of Provisioning
138	Jawaharlal Nehru Centre for Advanced Scientific Research, Jakkur Campus, Bangalore-560064.	BGTD	Pvt.	Commissioned	01-01-2020
139	National law School of India University, Bangalore-5600072	BGTD	Govt.	Commissioned	01-01-2020
140	Swamy Viekananda Yoga Anusandana Samsthana	BGTD	Pvt.	Commissioned	01-01-2020
141	Christ University, Bangalore	BGTD	Pvt.	Commissioned	01-01-2020
142	J.S.S University	KARNATAKA	Pvt.	Commissioned	01-01-2020
143	Calicut University, Trichy Palary, Malapuram District, Kozhikode-673635	Kerela	Govt.	Commissioned	01-01-2020
144	Cochin University of Science & Technology, Kochi-682022	Kerela	Govt.	Commissioned	01-01-2020
145	Kannur University, Kannur-670562	Kerela	Govt.	Commissioned	01-01-2020
146	Kerala Agricultural University, Thrissur-680656	Kerela	Govt.	Commissioned	01-01-2020
147	Kerala University, Thiruvananthapuram-695034	Kerela	Govt.	Commissioned	01-01-2020
148	Mahatma Gandhi University, Kottayam-686560	Kerela	Govt.	Commissioned	01-01-2020
149	Shree Shankaracharya University of Sanskrit, Kalady	Kerela	Govt.	Commissioned	01-01-2020
150	NIT Calicut	Kerela	Govt.	Commissioned	01-01-2020
151	Central University of Kerala, Nayanmarmoola, Kasargode	Kerela	Govt.	Commissioned	01-01-2020
152	Kerala university of health and allied sciences ,Trisuur	Kerela	Govt.	Commissioned	01-01-2020

<b>S.No</b>	<b>Name of University</b>	<b>Name of Circle</b>	<b>Govt / Pvt</b>	<b>Status</b>	<b>Date of Provisioning</b>
153	National University of advanced legal studies,Ernakulam	Kerela	Govt.	Commissioned	01-01-2020
154	Indian Institute of Space Science and Technology (IIST) ,Valiamala, Trivandrum	Kerela	Govt.	Commissioned	01-01-2020
155	Kerala Kalamandalam university, Trissur	Kerela	Govt.	Commissioned	01-01-2020
156	Kerala Veterinary and Animal Sciences University, Pookod,waynad	Kerela	Govt.	Commissioned	01-01-2020
157	Kerala University of Fisheries and Ocean studies , Panangad	Kerela	Govt.	Commissioned	01-01-2020
158	Barkatullah University, Bhopal-462026	Madhya Pradesh	Govt.	Commissioned	01-01-2020
159	Devi Ahilya Vishwavidyalaya, Indore -452001	Madhya Pradesh	Govt.	Commissioned	01-01-2020
160	Indian Institute of Information Technology and Management, Gwalior	Madhya Pradesh	Govt.	Commissioned	01-01-2020
161	Lakshmi Bai National Institute of Physical Education, Gwalior-474002	Madhya Pradesh	Pvt.	Commissioned	01-01-2020
162	Makhanlal Chaturvedi Rashtriya Patrakarita National University Journalism, Bhopal-462039	Madhya Pradesh	Govt.	Commissioned	01-01-2020
163	M.P.Bhoj (open) University, Bhopal-462016	Madhya Pradesh	Govt.	Commissioned	01-01-2020
164	National Law Institute University, Bhaadbhada Road, Barker Kalan, Bhopal	Madhya Pradesh	Govt.	Commissioned	01-01-2020
165	Rajiv Gandhi Prodyogiki Vishwavidyalaya, Bhopal-462036	Madhya Pradesh	Govt.	Commissioned	01-01-2020

<b>S.No</b>	<b>Name of University</b>	<b>Name of Circle</b>	<b>Govt / Pvt</b>	<b>Status</b>	<b>Date of Provisioning</b>
166	NIT Bhopal	Madhya Pradesh	Govt.	Commissioned	01-01-2020
167	Awadesh Pratap Singh University, Rewa-486006	Madhya Pradesh	Govt.	Commissioned	01-01-2020
168	Jiwaji University, Gwalior-474011	Madhya Pradesh	Govt.	Commissioned	01-01-2020
169	Maharishi Mahesh Yogi Vedic Vishwavidyalaya, Jabalpur-482001	Madhya Pradesh	Govt.	Commissioned	01-01-2020
170	M.G. Gramodaya Vishwavidyalaya, Chitrakoot-485331, District Satna	Madhya Pradesh	Govt.	Commissioned	01-01-2020
171	Rani Durgavati Vishwavidyalaya, Jabalpur-482001	Madhya Pradesh	Govt.	Commissioned	01-01-2020
172	Vikram University, Ujjain-456010	Madhya Pradesh	Govt.	Commissioned	01-01-2020
173	Jaypee University of Engineering & Technology AB Road, Raghogarh, Distt, Guna-473226 Madya Pradesh	Madhya Pradesh	Govt.	Commissioned	01-01-2020
174	IIITDM, Jabalpur	Madhya Pradesh	Govt.	Commissioned	01-01-2020
175	School of Planning and Architecture, Bhopal	Madhya Pradesh	Govt.	Commissioned	01-01-2020
176	Dr. Babasaheb Ambedka Marathwada University, Aurangabad-431004	Maharashtra	Govt.	Commissioned	01-01-2020
177	Dr.Punjabrao Deshmukh Krishi Vidyapeeth, Akola-4444104	Maharashtra	Govt.	Commissioned	01-01-2020
178	Maharashtra University of Health Sciences, Nashik-42201	Maharashtra	Govt.	Commissioned	01-01-2020
179	Sant Gadge Baba Amravati Universtiy, Amravati-444602	Maharashtra	Govt.	Commissioned	01-01-2020
180	Shivaji University, Kolhapur-416004	Maharashtra	Govt.	Commissioned	01-01-2020

<b>S.No</b>	<b>Name of University</b>	<b>Name of Circle</b>	<b>Govt / Pvt</b>	<b>Status</b>	<b>Date of Provisioning</b>
181	Swami Ramanand Teerth Marathwada University, Nanded-431606	Maharashtra	Govt.	Commissioned	01-01-2020
182	Yashwant Rao Chavan Maharashtra Open University, Nashik-422222	Maharashtra	Govt.	Commissioned	01-01-2020
183	Dr. Babasaheb Ambedkar Technological University, Lonere-402103	Maharashtra	Govt.	Commissioned	01-01-2020
184	Bharati Vidyapeeth, Pune-411030.	Maharashtra	Govt.	Commissioned	01-01-2020
185	Datta Meghe Institute of Medical Sciences, Nagpur-440022	Maharashtra	Pvt.	Commissioned	01-01-2020
186	Dr. D.Y. Patil Vidyapeeth, Pimpri, Pune-411018	Maharashtra	Pvt.	Commissioned	01-01-2020
187	D.Y.Patil Education Society , Kolhapur	Maharashtra	Pvt.	Commissioned	01-01-2020
188	Kavi Kulguru Kalidas Sanskrit Vishwavidyalaya, Nagpur-441106	Maharashtra	Govt.	Commissioned	01-01-2020
189	Konkan Krishi Vidyapeeth, Dapoli, district Ratnagiri-415712	Maharashtra	Govt.	Commissioned	01-01-2020
190	Maharashtra Animal & Fishery Sciences University, Seminary Hills, Nagpur-440006	Maharashtra	Govt.	Commissioned	01-01-2020
191	Mahatma Gandhi antarrashtriya Hindi Vishwavidyalay, Wardha	Maharashtra	Govt.	Commissioned	01-01-2020
192	Mahatma Phule Krishi Vidyapeeth, Tahuri - 413722	Maharashtra	Govt.	Commissioned	01-01-2020
193	Marathwada Agricultural University, Parbhani-431402	Maharashtra	Govt.	Commissioned	01-01-2020
194	North Maharashtra University, Jalgaon-425001	Maharashtra	Govt.	Commissioned	01-01-2020

S.No	Name of University	Name of Circle	Govt / Pvt	Status	Date of Provisioning
195	Solapur University, Solapur Pune Road, Kegaon, Solapur-413255	Maharashtra	Govt.	Commissioned	01-01-2020
196	The Rashtrasant tukadoji Maharaj Nagpur University, Nagpur-440001 (M.S.)	Maharashtra	Govt.	Commissioned	01-01-2020
197	Krishna Institute of Medical Sciences, Karad, Satara.	Maharashtra	Pvt.	Commissioned	01-01-2020
198	Goa University, Bambolin,Goa	Maharashtra	Govt.	Commissioned	01-01-2020
199	NIT Goa	Maharashtra	Govt.	Commissioned	01-01-2020
200	Tripura University, Agartala-799130.	Tripura	Govt.	Commissioned	01-01-2020
201	NIT Agarthala	Tripura	Govt.	Commissioned	01-01-2020
202	Nagaland University, Nagaland-797001	Nagaland	Govt.	Commissioned	01-01-2020
203	Mizoram University, Aizawal-796012	Mizoram	Govt.	Commissioned	01-01-2020
204	North Eastern Hill University, Shilong-793022.	Meghalya	Govt.	Commissioned	01-01-2020
205	Martin Luther University ,barick Point ,Shillong	Meghalya	Govt.	Commissioned	01-01-2020
206	NIT, Shillong @ SVNIT Surat, Gujarath	Meghalya	Govt.	Commissioned	01-01-2020
207	Central Agricultural University, Imphal- 795004	Manipur	Govt.	Commissioned	01-01-2020
208	Manipur University, Imphal-795003	Manipur	Govt.	Commissioned	01-01-2020
209	NIT Manipur	Manipur	Govt.	Commissioned	01-01-2020
210	North Eastern Regional Institute of Science & Technology, Nirjuli, Itanagar, 791109.	Arunacahal Pradesh	Pvt.	Commissioned	01-01-2020
211	Rajiv Gandhi Univrsity, Itanagar-79112.	Arunacahal Pradesh	Govt.	Commissioned	01-01-2020
212	Kalinga Institutte of Industrial Technology, Bhubaneshwar-751024	Orissa	Pvt.	Commissioned	01-01-2020

<b>S.No</b>	<b>Name of University</b>	<b>Name of Circle</b>	<b>Govt / Pvt</b>	<b>Status</b>	<b>Date of Provisioning</b>
213	North Orissa University, Baripada, Kistrict Mayurbhanj-757003, Bhubaneswar	Orissa	Govt.	Commissioned	01-01-2020
214	Utkal University, Bhubaneswar-751004	Orissa	Govt.	Commissioned	01-01-2020
215	NIT Rourkela	Orissa	Govt.	Commissioned	01-01-2020
216	Shiksha O Anusandhan, Khandagiri, Bhubaneshwar	Orissa	Govt.	Commissioned	01-01-2020
217	Berhampur University, Berhampur -760007	Orissa	Govt.	Commissioned	01-01-2020
218	Biju Patnaik University of Technology, Rourkela	Orissa	Govt.	Commissioned	01-01-2020
219	Centurion University of Technology and Management, Village Alluri Nagar, Via- Uppalada, Paralakhemundi, Gajapati, 761 211	Orissa	Pvt.	Commissioned	01-01-2020
220	Orissa University of Agriculture & Technology, Bhubaneswar-751003	Orissa	Govt.	Commissioned	01-01-2020
221	Ravenshaw University, Cuttak-753003	Orissa	Govt.	Commissioned	01-01-2020
222	Sambalpur University, Sambalpur-768019	Orissa	Govt.	Commissioned	01-01-2020
223	Veer Surendra Sai University of Technology (VSSUT) , Burla, Dist: Sambalpur, Orissa	Orissa	Govt.	Commissioned	01-01-2020
224	Central University of Orissa	Orissa	Govt.	Commissioned	01-01-2020
225	Central University of Punjab, P.O. Box-55, Bathinda, Punjab	Punjab	Govt.	Commissioned	01-01-2020
226	Guru Nanak Dev University, Amritsar-143005	Punjab	Govt.	Commissioned	01-01-2020
227	Punjab Technical University, Jalandhar-144011	Punjab	Govt.	Commissioned	01-01-2020



<b>S.No</b>	<b>Name of University</b>	<b>Name of Circle</b>	<b>Govt / Pvt</b>	<b>Status</b>	<b>Date of Provisioning</b>
228	Punjabi University, Patiala-147002	Punjab	Govt.	Commissioned	01-01-2020
229	Sant Longowal Institute of Engineering and Technology (SLIET), Longowal, District Sangrur, Punjab	Punjab	Pvt.	Commissioned	01-01-2020
230	The Rajiv Gandhi National University of Law, Patiala-147001	Punjab	Govt.	Commissioned	01-01-2020
231	Thapar Institute of Engineering & Technology, Patiala-147004.	Punjab	Pvt.	Commissioned	01-01-2020
232	Punjab University, Chandigarh-160014	Punjab	Govt.	Commissioned	01-01-2020
233	Banasthali Vidyapeeth, Banasthali-304022.	Rajasthan	Pvt.	Commissioned	01-01-2020
234	Jai Narain Vyas University, Jodhpur-342001	Rajasthan	Govt.	Commissioned	01-01-2020
235	Rajasthan Agricultural University, Bikaner-334006	Rajasthan	Govt.	Commissioned	01-01-2020
236	NIIT University, Neemrana, Alwar, Rajasthan	Rajasthan	Pvt.	Commissioned	01-01-2020
237	IIT Jodhpur	Rajasthan	Govt.	Commissioned	01-01-2020
238	National Law University, Jodhpur-342004	Rajasthan	Pvt.	Commissioned	01-01-2020
239	Jyoti Vidyapeeth Women's University, Vedant Gyan Valley village, Jharna Matpala Jabner, Link Road NH-8, Jaipur, Rajasthan	Rajasthan	Pvt.	Commissioned	01-01-2020
240	Amity University, Rajasthan NH-11C, Kant Kalwar, Jaipur -303002, Rajasthan.	Rajasthan	Pvt.	Commissioned	01-01-2020
241	Institute of Advanced Studies in Education of Gandhi Vidya Mandir, Sardarshahr-331401.	Rajasthan	Pvt.	Commissioned	01-01-2020

S.No	Name of University	Name of Circle	Govt / Pvt	Status	Date of Provisioning
242	IIS Univesity, Gurukul Marg, Mansarovar, Jaipur, Rajasthan	Rajasthan	Pvt.	Commissioned	01-01-2020
243	Jagadguru Ramanadacharya Sanskrit University, 2-2 A Jhalana Doongri, Jaipur	Rajasthan	Govt.	Commissioned	01-01-2020
244	Jagannath University	Rajasthan	Pvt.	Commissioned	01-01-2020
245	Jain Vishva Bharati Institite, Ladnun-341306.	Rajasthan	Pvt.	Commissioned	01-01-2020
246	Jaipur National University, Jagatpura, Jaipur	Rajasthan	Govt.	Commissioned	01-01-2020
247	Janardan Rai Nagar Rajasthan Vidyapeeth, Udiapur-313001.	Rajasthan	Pvt.	Commissioned	01-01-2020
248	Jodhpur National University, Narnadi Jhanwar Road, Jodhpur-342001	Rajasthan	Pvt.	Commissioned	01-01-2020
249	LNM Institite of Information Technology, LNM Institute of Inforamation Technology, Gram-Rupa ki nagal, Post- sumel, Via Kanata, Dist. –Jaipur-303012	Rajasthan	Pvt.	Commissioned	01-01-2020
250	Maharana Pratap University of agriculture & Technology, Udaipur-313001	Rajasthan	Govt.	Commissioned	01-01-2020
251	Maharishi Dayanand saraswati University, Ajmer-305009	Rajasthan	Govt.	Commissioned	01-01-2020
252	Mewar University, Chittorgarh	Rajasthan	Govt.	Commissioned	01-01-2020
253	Mahathma Jyothirao Phule university	Rajasthan	Pvt.	Commissioned	01-01-2020
254	Mody Institite of Technology and Science, Lakshmangarh, District Sikar	Rajasthan	Pvt.	Commissioned	01-01-2020
255	Mohan Lal Sukhadia University, Udaipur	Rajasthan	Govt.	Commissioned	01-01-2020

<b>S.No</b>	<b>Name of University</b>	<b>Name of Circle</b>	<b>Govt / Pvt</b>	<b>Status</b>	<b>Date of Provisioning</b>
256	NIMS University, Shobha Nagar, Jipur-303001	Rajasthan	Pvt.	Commissioned	01-01-2020
257	Rajasthan ayurveda University, Jodhpur	Rajasthan	Govt.	Commissioned	01-01-2020
258	Rajasthan Technical University, Akelgarh, Rawat Bhata Road, Kota-324010	Rajasthan	Govt.	Commissioned	01-01-2020
259	Rajasthan University of Health Sciences, B-1, Swai Man Singh Road (Opp SMS Hospital), Jaipur	Rajasthan	Govt.	Commissioned	01-01-2020
260	Singhania University, Pacheribari, Jhunjunu	Rajasthan	Pvt.	Commissioned	01-01-2020
261	Sir Padmapat Singania University, Bhatewar Udaipur-313601	Rajasthan	Pvt.	Commissioned	01-01-2020
262	Suresh Gyan Vihar University, Mahal Jagatpoura, Jaipur, Rajasthan	Rajasthan	Pvt.	Commissioned	01-01-2020
263	University of Bikaner, 23, Civil Lines, Bikaner (Maharaja Ganga singh University)	Rajasthan	Govt.	Commissioned	01-01-2020
264	University of Kota	Rajasthan	Govt.	Commissioned	01-01-2020
265	Vardhman Mahaveer Open University, Kota-324010	Rajasthan	Govt.	Commissioned	01-01-2020
266	Rajasthan veterenary & Animal science university	Rajasthan	Govt.	Commissioned	01-01-2020
267	Pacific Acadamy of Higher Education & Research University, Udaipur	Rajasthan	Pvt.	Commissioned	01-01-2020
268	Central University of Rajasthan	Rajasthan	Govt.	Commissioned	01-01-2020
269	Bhagvanth University, Siker Road, Ajmeer, Rajasthan	Rajasthan	Pvt.	Commissioned	01-01-2020
270	Amrita Vishwa Vidyapeetham, Coimbatore-641105.	Tamilnadu	Pvt.	Commissioned	01-01-2020

<b>S.No</b>	<b>Name of University</b>	<b>Name of Circle</b>	<b>Govt / Pvt</b>	<b>Status</b>	<b>Date of Provisioning</b>
271	Anna University, GCT Campus, Thandagam Road, Coimbarote-641013	Tamilnadu	Govt.	Commissioned	01-01-2020
272	Avinashilingam Institute for Home Science & Higher Education for Women, Coimbatore-641043.	Tamilnadu	Pvt.	Commissioned	01-01-2020
273	Bharathiar University, Coimbatore-641046	Tamilnadu	Govt.	Commissioned	01-01-2020
274	Central University of Tamil Nadu, C/o Collectorate Annexe, Tiruvarur-610001	Tamilnadu	Govt.	Commissioned	01-01-2020
275	Gandhigram Rural Institute, Gandhigram-624302.	Tamilnadu	Pvt.	Commissioned	01-01-2020
276	Karunya Institute of Technology and Sciences, Karunya Nagar, Coimbtore-64114	Tamilnadu	Pvt.	Commissioned	01-01-2020
277	Madhurai Kamaraj University	Tamilnadu	Govt.	Commissioned	01-01-2020
278	MotherTeresa Women's University, Kodaikanal-624102	Tamilnadu	Govt.	Commissioned	01-01-2020
279	Noorul Islam Centre for Higher Education, Kumaracoil, Thuckalay, Kanyakumari District-629175. .	Tamilnadu	Pvt.	Commissioned	01-01-2020
280	Periyar Maniammai Institute of Science & Technology (PMIST), Periyar Nagar, Vallam, Thanjavur-613403	Tamilnadu	Pvt.	Commissioned	01-01-2020
281	Shanmugha Arts, Science, Technology, Research & Academy (SASTRA), Thanjavur-613402.	Tamilnadu	Pvt.	Commissioned	01-01-2020
282	Tamilnadu agricultural University, Coimbatore-641003	Tamilnadu	Govt.	Commissioned	01-01-2020

<b>S.No</b>	<b>Name of University</b>	<b>Name of Circle</b>	<b>Govt / Pvt</b>	<b>Status</b>	<b>Date of Provisioning</b>
283	Alagappa University, Alagappa Nagar, Karaaikudi-630003	Tamilnadu	Govt.	Commissioned	01-01-2020
284	Vinayaka Mission's Research Foundation, Salem-636308.	Tamilnadu	Pvt.	Commissioned	01-01-2020
285	Manonmaniam Sundarnar University, Thirunelveli-627012.	Tamilnadu	Govt.	Commissioned	01-01-2020
286	Anna University, Tiruchirapalli	Tamilnadu	Govt.	Commissioned	01-01-2020
287	Anna University of Technology, Madurai	Tamilnadu	Govt.	Commissioned	01-01-2020
288	Annamalai University, Annamalainagar-608002	Tamilnadu	Govt.	Commissioned	01-01-2020
289	Bharathidasan University, Tiruchirappalli-620024	Tamilnadu	Govt.	Commissioned	01-01-2020
290	Kalasalingam Academy of Research and Higher Education, Anand Nagar, krishnankoil, Virudhunagar-626190, via Srivilliputhur	Tamilnadu	Pvt.	Commissioned	01-01-2020
291	Karpagam Academy of Higher Education, Pollachi Main Road, Coimbatore	Tamilnadu	Pvt.	Commissioned	01-01-2020
292	Pondicherry University, Pondicherry	Pondicherry/ Tamilnadu	Govt.	Commissioned	01-01-2020
293	Periyar University, Salem-636011	Tamilnadu	Govt.	Commissioned	01-01-2020
294	Tamil University, Thanjavur-613005	Tamilnadu	Govt.	Commissioned	01-01-2020
295	Thiruvalluvar University, fort Vellore-632004	Tamilnadu	Govt.	Commissioned	01-01-2020
296	NIT Trichy	Tamilnadu	Govt.	Commissioned	01-01-2020
297	IIITDM, Kancheepuram	Chennai	Govt.	Commissioned	01-01-2020
298	NIT Pondicherry	Pondicherry/ Tamilnadu	Govt.	Commissioned	01-01-2020

<b>S.No</b>	<b>Name of University</b>	<b>Name of Circle</b>	<b>Govt / Pvt</b>	<b>Status</b>	<b>Date of Provisioning</b>
299	Madras University, Chennai-600005 .	Chennai	Govt.	Commissioned	01-01-2020
300	S.R.M. Institute of Sciences and Technology, Chennai-600033.	Chennai	Pvt.	Commissioned	01-01-2020
301	Sri Chandrasekharandra Saraswati Vishwa Mahavidyalaya, Kancheepuram-631651.	Chennai	Pvt.	Commissioned	01-01-2020
302	Tamilnadu Dr. Ambedkar Law University, Chennai-600028	Chennai	Pvt.	Commissioned	01-01-2020
303	Anna University of Technology, CPT Campus, Tharamani, Chennai-13	Chennai	Govt.	Commissioned	01-01-2020
304	B.S. abdur Rahman Institute of Science and Technology, vandalur, Chennai	Chennai	Pvt.	Commissioned	01-01-2020
305	Acedemy of Maritime Education and Training, 5107, H2,2nd Avenue, 1st Floor, Anna Nagar, Chennai-600040.	Chennai	Pvt.	Commissioned	01-01-2020
306	Bharath Institute of Higher Education & Research, Chennai-600073	Chennai	Pvt.	Commissioned	01-01-2020
307	Rajiv Gandhi National Institute of Youth Development, Sriperumbudur, 602105	Chennai	Pvt.	Commissioned	01-01-2020
308	Sathyabama Institute of Science and Technology, Chennai-600119.	Chennai	Pvt.	Commissioned	01-01-2020
309	Saveetha Institute of Medical and Technical Sciences, Post Box No. 6 No.162, Poonamalle High Road, Velappanchavadi, Chennai-600077	Chennai	Pvt.	Commissioned	01-01-2020

<b>S.No</b>	<b>Name of University</b>	<b>Name of Circle</b>	<b>Govt / Pvt</b>	<b>Status</b>	<b>Date of Provisioning</b>
310	Sri Ramachandra Medical College and Research Institute, chennai-600116.	Chennai	Pvt.	Commissioned	01-01-2020
311	Tamilnadu Veterinary & Animal sciences University, chennai-600051	Chennai	Govt.	Commissioned	01-01-2020
312	St. Peter's Institute of Higher Education and Research, Chennai	Chennai	Pvt.	Commissioned	01-01-2020
313	Vel's Institute of Science, Technology & advanced Studies(VISTAS), Pallavaram, Chennai,	Chennai	Pvt.	Commissioned	01-01-2020
314	Vel Tech Rangarajan Dr. Sagunthala R & D Institute of Science and Technology, Chennai	Chennai	Pvt.	Commissioned	01-01-2020
315	Indian Maritime University	Chennai	Govt.	Commissioned	01-01-2020
316	Vellore Institute of Technology, Vellore	Tamilnadu	Pvt.	Commissioned	01-01-2020
317	University of Allahabad, Allahabad-211002 .	Uttar Pradesh(E)	Govt.	Commissioned	01-01-2020
318	Banaras Hindu University, Varanasi-221005	Uttar Pradesh(E)	Govt.	Commissioned	01-01-2020
319	Bundelkhand University, Jhansi-284128.	Uttar Pradesh(E)	Govt.	Commissioned	01-01-2020
320	Central Institute of Higher Tibetan studies, Sarnath, Varanasi-221007.	Uttar Pradesh(E)	Pvt.	Commissioned	01-01-2020
321	Chatrapati sahuji Maharaj Kanpur University, Kanpur-208024	Uttar Pradesh(E)	Govt.	Commissioned	01-01-2020
322	Deen Dayal Upadhyay gorakhpur University, Gorakhpur-273009	Uttar Pradesh(E)	Govt.	Commissioned	01-01-2020
323	Dr. Shukantla Mishra Uttar Pradesh Viklang Vishwavidyalaya, Lucknow	Uttar Pradesh(E)	Govt.	Commissioned	01-01-2020
324	Indian Institute of Information Technology, Allahabad-211002.	Uttar Pradesh(E)	Govt.	Commissioned	01-01-2020

S.No	Name of University	Name of Circle	Govt / Pvt	Status	Date of Provisioning
325	Veer Bahadur Singh Purvanchal University, Jaunpur-222002	Uttar Pradesh(E)	Govt.	Commissioned	01-01-2020
326	University of Lucknow	Uttar Pradesh(E)	Govt.	Commissioned	01-01-2020
327	Sam Higginbotham Institute of Agriculture, Technology and Sciences, Allahabad-211007	Uttar Pradesh(E)	Pvt.	Commissioned	01-01-2020
328	Dr Ram Manohar Lohia Awadh University, Faizabad-224001	Uttar Pradesh(E)	Govt.	Commissioned	01-01-2020
329	Dr. Ram Manohar Lohiya National Law University, Sector-D-1, L.D. 'A', Kanpur Road Scheme, Lucknow	Uttar Pradesh(E)	Govt.	Commissioned	01-01-2020
330	Integral University, Kursi Road, Lucknow-226026	Uttar Pradesh(E)	Pvt.	Commissioned	01-01-2020
331	King Georges Medical University, Lucknow-226003	Uttar Pradesh(E)	Govt.	Commissioned	01-01-2020
332	Mahatma Gandhi Kashi Vidyapeeth, Varanasi-221002	Uttar Pradesh(E)	Govt.	Commissioned	01-01-2020
333	Narendra Deo University of Agriculture & Technology, Faizabad-224229	Uttar Pradesh(E)	Govt.	Commissioned	01-01-2020
334	Nehru Gram Bharti Vishwavidyalaya, Kotwa-Jamunipur, Dubwali Disst., Allahabad, Uttar Pradesh	Uttar Pradesh(E)	Pvt.	Commissioned	01-01-2020
335	Sampurananand Sanskrit Vishwavidyalaya, Varanasi-221002	Uttar Pradesh(E)	Govt.	Commissioned	01-01-2020
336	U.P. King George's University of Dental science, Lucknow-226003	Uttar Pradesh(E)	Govt.	Commissioned	01-01-2020
337	U.P Rajarshi Tandon Open University, 17, Maharshi Dayanand Marg, (Thornhill Road), Allahabad-211001	Uttar Pradesh(E)	Govt.	Commissioned	01-01-2020



S.No	Name of University	Name of Circle	Govt / Pvt	Status	Date of Provisioning
338	Bhatkhande Music Institute, Kaiserbag, Lucknow-226001	Uttar Pradesh(E)	Govt.	Commissioned	01-01-2020
339	U.P.Technical University (GBTU) Lucknow	Uttar Pradesh(E)	Govt.	Commissioned	01-01-2020
340	Choudhary Charan Singh University,Meerut-250005	Uttar Pradesh(W)	Govt.	Commissioned	01-01-2020
341	Dr. B.R. Ambedkar University, Agra-282004	Uttar Pradesh(W)	Govt.	Commissioned	01-01-2020
342	Gautam Buddha University, Greater Noida, District-Gautam Budh Nagar, Uttar Pradesh-201308	Uttar Pradesh(W)	Govt.	Commissioned	01-01-2020
343	M. J.P. Rohilkhand University, Bareilly-226006	Uttar Pradesh(W)	Govt.	Commissioned	01-01-2020
344	Sardar Vallabh Bhai Patel University of Agriculture & Technology, Meerut-250110	Uttar Pradesh(W)	Govt.	Commissioned	01-01-2020
345	Sharda University, Gautam Budh Nagar, Uttar Pradesh	Uttar Pradesh(W)	Pvt.	Commissioned	01-01-2020
346	Shobit Institute of Engineering & Technology, Dulhera Marg, Roorkee Road, Meerut-250010	Uttar Pradesh(W)	Pvt.	Commissioned	01-01-2020
347	Amity University, Noida	Uttar Pradesh(W)	Pvt.	Commissioned	01-01-2020
348	Jaypee Institute of Information Technology, A-10, Sector62, Noida-201307	Uttar Pradesh(W)	Pvt.	Commissioned	01-01-2020
349	Swami Vivekanand Subharit University, Subharti Puram, Delhi-Haridwar By Pass Road Meerut	Uttar Pradesh(W)	Pvt.	Commissioned	01-01-2020
350	Teerthanker Mahaveer University, Delhi Road, Moradabad	Uttar Pradesh(W)	Govt.	Commissioned	01-01-2020
351	Mohd. Ali Jauhar University Rampur	Uttar Pradesh(W)	Pvt.	Commissioned	01-01-2020

<b>S.No</b>	<b>Name of University</b>	<b>Name of Circle</b>	<b>Govt / Pvt</b>	<b>Status</b>	<b>Date of Provisioning</b>
352	Mangalayatan University	Uttar Pradesh(W)	Pvt.	Commissioned	01-01-2020
353	Santosh University, Santoshnagar, Ghaziabad	Uttar Pradesh(W)	Pvt.	Commissioned	01-01-2020
354	Invertis University	Uttar Pradesh(W)	Pvt.	Commissioned	01-01-2020
355	GLA University	Uttar Pradesh(W)	Pvt.	Commissioned	01-01-2020
356	Doon University, Campus Office, 388/2, Indira Nagar Dehradun.	Uttarakhand	Pvt.	Commissioned	01-01-2020
357	Kumaun University, Nainital-263001	Uttarakhand	Govt.	Commissioned	01-01-2020
358	Forest Research Institute, Dehradun-248195.	Uttarakhand	Pvt.	Commissioned	01-01-2020
359	Hemwati Nandan Bahuguna Garhwal University, Srinagar-246174.	Uttarakhand	Govt.	Commissioned	01-01-2020
360	HIHT University, Swami Rama Nagar, Jolly Grant, P.O. Doiwala, Dehradun	Uttarakhand	Pvt.	Commissioned	01-01-2020
361	University of Petroleum and Energy Studies, Building No.-7, Street No. 1, Vasant Vihar Enclave, Dehradun-284006	Uttarakhand	Pvt.	Commissioned	01-01-2020
362	Uttarakhand Technical University, Dehradun	Uttarakhand	Govt.	Commissioned	01-01-2020
363	Himgiri Nabh Vishwavidyalaya (University in the Sky), Dehradun.	Uttarakhand	Pvt.	Commissioned	01-01-2020
364	Gurukul Kangri Vishwavidyalaya, Haridwar-249404.	Uttarakhand	Pvt.	Commissioned	01-01-2020
365	Graphic Era University, 566/6 Bell Road, Clement Town, Dehradun	Uttarakhand	Pvt.	Commissioned	01-01-2020

S.No	Name of University	Name of Circle	Govt / Pvt	Status	Date of Provisioning
366	Dev Sanskriti Vishwavidyalaya, Gayatrikunj, Shantikunj, Haridwar-249411.	Uttarakhand	Pvt.	Commissioned	01-01-2020
367	Bidhan Chandra Krishi Vishwavidyalaya, Mohanpur, Nadia	Kolkata Telephones	Govt.	Commissioned	01-01-2020
368	Burdwan University, Kolkata-700032	West Bengal	Govt.	Commissioned	01-01-2020
369	Kalyani University, Kalyani-741235	Kolkata Telephones	Govt.	Commissioned	01-01-2020
370	The Bengal Engineering & Science University, Shibpur, Howrah	Kolkata Telephones	Govt.	Commissioned	01-01-2020
371	Vidya Sagar University, Midnapor-721102	West Bengal	Govt.	Commissioned	01-01-2020
372	West Bengal State University , Barasat Govt. College, Annexure Building, 10, KNC Road, Kolkata-700124.	Kolkata Telephones	Govt.	Commissioned	01-01-2020
373	West Bengal University of Technology, salt lake, Kolkata-	Kolkata Telephones	Govt.	Commissioned	01-01-2020
374	NIT Durgapur	West Bengal	Govt.	Commissioned	01-01-2020
375	Rabindra Bharati University, Kolkata-700050	Kolkata Telephones	Govt.	Commissioned	01-01-2020
376	Aliah University, Kolkota	Kolkata Telephones	Govt.	Commissioned	01-01-2020
377	Calcutta University, Kolkata-700073	Kolkata Telephones	Govt.	Commissioned	01-01-2020
378	Gaur Banga University, Rabindra Avenue, Malda College Campus, P.O. & Disst-Malda-732101,	West Bengal	Govt.	Commissioned	01-01-2020
379	Jadavpur University, Calcutta-700073	Kolkata Telephones	Govt.	Commissioned	01-01-2020
380	Netaji Subhash Open Univesity, Kolkata-700020	Kolkata Telephones	Govt.	Commissioned	01-01-2020

<b>S.No</b>	<b>Name of University</b>	<b>Name of Circle</b>	<b>Govt / Pvt</b>	<b>Status</b>	<b>Date of Provisioning</b>
381	Vishwa Bharati University, Shanti Niketan-731235	West Bengal	Govt.	Commissioned	01-01-2020
382	The West Bengal University of Health Sciences, DD-36, Sector-1, Salt Lake, Kolkata-700064	Kolkata Telephones	Govt.	Commissioned	01-01-2020
383	Sikkim University, Gangtok	West Bengal (Sikkim)	Govt.	Commissioned	01-01-2020
384	West Bengal State University of Animal & Fishery Science, Belgauchi, West Bengal	Kolkata Telephones	Govt.	Commissioned	01-01-2020
385	Ramakrishna Mission Vivekananda Educational Research Institute, Belurumath, Howrah	Kolkata Telephones	Govt.	Commissioned	01-01-2020
386	Sikkim- Manipal University of Health, Medical & Technological Sciences, Gangtok-737101.	West Bengal(Sikkim)	Pvt.	Commissioned	01-01-2020
387	NIT, Sikkim	West Bengal (Sikkim)	Govt.	Commissioned	01-01-2020
388	North Bengal University, Raja Ram Mohanpur, Darjeeling	West Bengal	Govt.	Commissioned	01-01-2020

## Appendix-IV

S.No.	State / UT	University/ University Level Institutions	Category
1	Bihar	National Institute of Technology, Patna	NIT
2	Himachal Pradesh	National Institute of Technology, Hamirpur	NIT
3	Karnataka	National Institute of Mental Health and Neuro Sciences, Bengaluru	Deemed University
4	Maharashtra	Visvesvaraya National Institute of Technology, Nagpur	NIT
5	Punjab	B. R. Ambedkar National Institute of Technology, Jalandar	NIT
6	Chhattisgarh	National Institute of Technology, Raipur	NIT
7	Haryana	National Institute of Technology (NIT), Kurukshetra	NIT
8	Gujarat	National Institute Of Technology, Surat	NIT
9	Delhi	Indraprastha Institute of Information Technology, Okhla	State University
10	Rajasthan	University of Rajasthan, Jaipur	State University
11	Delhi	Jawahar Lal Nehru University, Munirka	Central University
12	Uttar Pradesh	Aligarh Muslim University, Aligarh	Central University
13	Jammu & kashmir	University of Jammu, Jammu	State University
14	Andhra Pradesh	University of Hyderabad, Hyderabad	Central University
15	Uttar Pradesh	Indian Institute of Technology, BHU, Varanasi	IIT
16	Delhi	Delhi University, Delhi	Central University
17	Maharashtra	Tata Institute of Fundamental Research, Mumbai	Deemed University
18	Uttar Pradesh	Dayalbagh Educational Institute, Allahabad	Deemed University
19	Maharashtra	Indian Institute of Technology (IIT), Mumbai	IIT
20	Assam	Indian Institute of Technology (IIT), Guwahati	IIT
21	Tamilnadu	Indian Institute of Technology (IIT), Chennai	IIT
22	Delhi	Indian Institute of Technology (IIT), Delhi	IIT
23	Uttar Pradesh	Indian Institute of Technology (IIT), Kanpur	IIT

<b>S.No.</b>	<b>State / UT</b>	<b>University/ University Level Institutions</b>	<b>Category</b>
24	West Bengal	Indian Institute of Technology (IIT), Kharagpur	IIT
25	Uttarakhand	Indian Institute of Technology (IIT), Roorkee	IIT
26	Bihar	Indian Institute of Technology (IIT), Patna	IIT
27	Andhra Pradesh	Indian Institute of Technology (IIT), Hyderabad	IIT
28	Odisha	Indian Institute of Technology (IIT), Bhubaneswar	IIT
29	Punjab	Indian Institute of Technology (IIT), Ropar	IIT
30	Gujarat	Indian Institute of Technology (IIT), Gandhinagar	IIT
31	Madhya Pradesh	Indian Institute of Technology (IIT), Indore	IIT
32	Himachal Pradesh	Indian Institute of Technology (IIT), Mandi	IIT
33	Uttar Pradesh	Motilal Nehru National Institute of Technology, Allahabad	NIT
34	Rajasthan	Malaviya National Institute of Technology, Jaipur	NIT
35	Karnataka	Indian Institute of Science, Bangalore	Deemed University
36	Tamilnadu	Anna University, Chennai	State University
37	Andhra Pradesh	Acharya NG Ranga Agricultural University, Rajendranagar	SAU
38	Assam	Assam Agricultural University, Jorhat	SAU
39	Madhya Pradesh	Jawaharlal Nehru Krishi Vishwavidyalaya, Jabalpur	SAU
40	Uttar Pradesh	Chandra Shekhar Azad University of Agriculture & Technology, Kanpur	SAU
41	Maharashtra	University of Pune, Pune	State University
42	Chandigarh (U.T)	Punjab Engineering College (PEC), University of Technology, Chandigarh	Deemed University
43	Gujarat	Anand Agricultural University, Anand	SAU
44	Delhi	Delhi Technical University , New Delhi	State University

<b>S.No.</b>	<b>State / UT</b>	<b>University/ University Level Institutions</b>	<b>Category</b>
45	Uttar Pradesh	Chhatrapati Sahuji Maharaj Medical University (CSMMU), Lucknow	State University
46	Assam	Gauhati University, Guwahati	State University
47	Uttar Pradesh	Babasaheb Bhimrao Ambedkar University, Lucknow	Central University
48	Chandigarh (U.T)	Panjab University, Chandigarh	State University
49	Tamilnadu	National Institute of Technology, Tiruchi	NIT
50	Jammu & Kashmir	National Institute of Technology, Srinagar	NIT
51	West bengal	National Institute of Technology, Durgapur	NIT
52	Gujarat	Junagadh Agricultural University, Junagadh	SAU
53	Uttar Pradesh	UP Pandit Deen Dayal Upadhaya Pashu Chikitsa Vigyan Vishwa Vidhyalaya evam Go Anusandhan Sansthan, Mathura	SAU
54	Gujarat	Navsari Agricultural University, Navsari	SAU
55	Madhya Pradesh	Rajmata Vijayaraje Scindia Krishi Vishwa Vidhyalaya, Gwalior	SAU
56	Karnataka	TIFR-Centre for Applicable Mathematics, Banglore	Deemed University
57	Bihar	Bihar Agricultural University, Bhagalpur	SAU
58	Uttarakhand	Uttarakhand Open University, Nainital	State University
59	Delhi	Institute of Liver and Biliary Sciences, Vasant Kunj	Deemed University
60	Delhi	Bharat Ratna Dr. Bhim Rao Ambedkar University, Dwarka	State University
61	Madhya Pradesh	National Judicial Academy, Bhopal	State University
62	West Bengal	Presidency University, Kolkata	State University
63	Delhi	South Asian University, New Delhi	Central University
64	Andhra Pradesh	Dr. Y.S.R Horticulture University ,Tadepalligudem	SAU
65	Himachal Pradesh	Chaudhary Sarwan Kumar Himachal Pradesh Krishi Vishvavidyalaya , Kangra	SAU
66	Tamilnadu	Dr.M.G.R. Medical University, Chennai	State University

S.No.	State / UT	University/ University Level Institutions	Category
67	Punjab	Guru Angad Dev Veterinary and Animal Sciences University, Ludhiana	State University
68	Delhi	Delhi University, New Delhi	Central University
69	Delhi	National Museum Institute of History of Art, Conservation and Museology, New Delhi	Deemed University
70	Delhi	National School of Drama , New Delhi	Deemed University
71	Meghalaya	North Eastern Hill University, Meghalaya	Central University
72	Karnataka	Rajiv Gandhi University of Health Sciences, Bangalore	State University
73	Himachal Pradesh	Dr. Y.S.Parmar University of Horticulture & Forestry, Nauni	State University
74	Punjab	Punjab Agricultural University, Ludhiana	State University
75	Madhya Pradesh	The Indira Gandhi National Tribal University, Amarkantak	Central University
76	Madhya Pradesh	Dr. Harisingh Gour Vishwavidyalaya, Sagar	Central University
77	Andhra Pradesh	Sri Venkateswara Vedic University, Tirupati	State University
78	Andhra Pradesh	Sri Venkateswara Veterinary University, Tirupati	SAU
79	Andhra Pradesh	Adikavi Nannaya University, Rajahmundry	State University
80	Andhra Pradesh	Rayalaseema University, Kurnool	State University
81	Andhra Pradesh	Palamuru University, Mahabubnagar	State University
82	Andhra Pradesh	Dr. B.R. Ambedkar University, Etcherla	State University
83	Chhattisgarh	Indira Gandhi Krishi Vishwavidyalaya, Raipur	SAU
84	Chhattisgarh	Indira Kala Sangeet Vishwavidyalaya, Rajnandgaon	State University
85	Chhattisgarh	Bastar Vishwavidyalaya, Bastar	State University
86	Chhattisgarh	Sarguja University, Ambikapur	State University
87	Haryana	Chaudhary Charan Singh Haryana Agriculture University, Hisar	SAU
88	Jharkhand	Birsa Agricultural University, Ranchi	SAU



S.No.	State / UT	University/ University Level Institutions	Category
89	Karnataka	University of Agricultural Sciences, Bangalore	SAU
90	Odisha	National Law University, Cuttack	State University
91	Punjab	Baba Farid University of Health Sciences, Faridkot	State University
92	Tamilnadu	Tamil Nadu Open University, Chennai	State University
93	Tamilnadu	Tamil Nadu Teachers Education University, Chennai	State University
94	West Bengal	Uttar Banga Krishi Vishwavidyalaya	SAU
95	West Bengal	The West Bengal National University of Juridical Sciences, Kolkata	State University
96	Andhra Pradesh	Damodaram Sanjivayya National Law University, Visakhapatnam	State University
97	Andhra Pradesh	Jawaharlal Nehru Architecture and Fine Arts University, Hyderabad	State University
98	Tamilnadu	TamilNadu Physical Education and Sports University	State University
99	Jammu & Kashmir	Sher-e-Kashmir University of Agricultural Sciences and Technology of Kashmir, Jammu	State University
100	Maharashtra	Gokhale Institute of Politics and Economics, Pune	Deemed University
101	Arunachal Pradesh	National Institute of Technology, Arunachal Pradesh	NIT
102	Maharashtra	MGM Institute of Health Science, Navi Mumbai	Deemed University
103	Maharashtra	SNDT Women's University, Mumbai	State University
104	Assam	Bodoland University, Kokrajhar	State University
105	Delhi	National Institute of Technology, Delhi	NIT
106	Himachal Pradesh	Himachal Pradesh Technical University, Hamirpur	State University
107	Chhattisgarh	Chhattisgarh Kamdhenu Vishwavidyalaya, Anjora	State University
108	Assam	National Law University and Judicial Academy, Guwahati	State University
109	Karnataka	Rani Chennamma University, Belagavi	State University

<b>S.No.</b>	<b>State / UT</b>	<b>University/ University Level Institutions</b>	<b>Category</b>
110	Karnataka	Vijayanagara Sri Krishna Devaraya University, Bellary	State University
111	Mizoram	National Institute of Technology, Aizawl	NIT
112	Meghalaya	National Institute of Technology, Shillong	NIT
113	Nagaland	National Institute of Technology, Dimapur	NIT
114	Gujarat	Gujarat Forensic Sciences University, Gandhinagar	State University
115	Maharashtra	Deccan College Post Graduate and Research Institute, Pune	Deemed University
116	Haryana	National Institute of Food Technology Entrepreneurship and Management	Deemed University
117	Uttarakhand	National Institute of Technology, Uttarakhand	NIT
118	Chhattisgarh	Bilaspur University, Bilaspur	State University
119	Karnataka	University of Agricultural & Horticultural Sciences, Shimoga	State University
120	Karnataka	University of Agricultural Sciences Raichur	State University
121	Delhi	Indira Gandhi Delhi Technical University for Women, Kashmere Gate (formely Indira Gandhi Institute of Technology)	State University
122	Uttarakhand	Uttarakhand University of Horticulture and Forestry, Bharsar Pauri Garhwal	State University
123	Rajasthan	Sri Karan Narendra Agriculture University	SAU
124	Assam	Cotton College State University	State University
125	Bihar	Maulana National Azad Urdu University campus Darbhanga	Central University
126	Haryana	Indira Gandhi University, Rewari	State University
127	Andhra Pradesh	Nizam's Institute of Medical Sciences, Hyderabad	State University

## Appendix-V

<b>MHRD Institutions in J&amp;K</b>	
1	National Institute of Technology Hazaratbal, SRINAGAR - 190006, J&K
2	Central University of Kashmir, Bagi-Hyder, Hyderpora, Srinagar-190 014
3	Central University of Jammu
<b>MHRD Institutions in North East including Sikkim</b>	
1	National Institute of Technology, Silchar - 788010, ASSAM
2	Assam University SILCHAR-788011
3	Tezpur University, NAPPAM, Dist. Sonitpur, Tezpur-784 025 Assam
4	Indian Institute of Technology (IIT) North Guwahati, GUWAHATI – 781039
5	North Eastern Regional Institute of Science & Technology (NERIST), Nirjuli - 791110 (Itanagar), Arunachal Pradesh
6	National Institute of Technology, Yupia, District Papum Pare, Arunachal Pradesh - 791112.
7	Rajiv Gandhi University, Itanagar– 791112, Arunachal Pradesh
8	National Institute of Technology, Nagaland
9	Nagaland University, Kohima-797001 Nagaland
10	Manipur University, Canchipur Imphal - 795003
11	National Institute of Technology, Manipur
12	Mizoram University, P.B.No.190, Aizawl - 796012. Mizoram
13	National Institute of Technology, Mizoram, Chaltlang, Aizawl-796012.
14	National Institute of Technology, Meghalaya
15	North Eastern Hill University, Lower Lachumere, Shillong-793022
16	Rajiv Gandhi Indian Institute of Management, Mayurbhanj Complex Shillong
17	National Institute of Technology, Agartala, Tripura
18	Tripura University, Suryamaninagar Agartala -799130
19	National Institute of Technology, Sikkim, Barfung Block, Ravangla Sub-Division, South Sikkim - 737 139.
20	Sikkim University, C/o Youth Hostel, 6th Mile, Tadong Gangtok – 737102,Sikkim

General Manager (CFA)  
4<sup>th</sup> Floor, CTO Building,  
8-Red Cross Place, Kolkata-700 001  
Phone: +91-33-22482410 Fax: +91-3322435011  
Fax:+91-33-22107124



भारत संचार निगम लिमिटेड  
(भारत सरकार का उपक्रम)  
**BHARAT SANCHAR NIGAM LIMITED**  
(A Govt. of India Enterprise)

1

No: ENG-II/W-9256/NMEICT/2013-14

Dated: 22<sup>th</sup> Jan, 2014

To,

The P.G.M.(NWP-BB)  
Corporate office, BSNL  
Bharat Sanchar Bhawan, Janpath  
New Delhi – 110 001

**Subject:** Techno-Commercial Proposal for formation of OFC ring for the 1 GE link of NIT, Sikkim under NMEICT Project.

**Reference:** As per decision in the NMEICT project meeting at Guwahati on 03.01.14

As per the decision in the meeting on NMEICT at Guwahati on 03.01.14, a Techno-commercial proposal for NIT Ravangla 1GE connectivity is given below:

Existing route is Ravangla- Temi (via Damthang)-Singtam (diagram at Annexure I). Alternate proposed route (**ring number-1**) is Ravangla- Temi (Direct new proposed AOFC route)-Singtam-Namthang (via Rangpo) – Namchi - Ravangla (via Damthang). This new ring would be built up to Gangtok via **ring number-2 "Gangtok- Penagla- Tintek- Singtam- Ranipool"**, as proposed in the diagram at Annexure I. The expenditure involved for ring 1 & 2 will be approximately Rs. 262.48 lakhs (a detail calculation of the expenditure involved including equipment cost is given in **Annexure-II**). The OFC work (dotted lines) shown in ring-2 is under execution by ETP through Sikkim State Government which is not included in the techno-commercial calculation.

For providing stable connectivity to the NIT, Ravangla replacements of some of the damaged portions of the existing OFC route is required as shown in **Annexure III**. The expenditure involved will be approximately Rs. 29.047 lakhs (a detail calculation is shown in Annexure- III).

If the above job is done and the connectivity of the NIT with the NIC is migrated to L2 VPN through TIER 1 SW at Gangtok ETR, to be installed (requisition for one TIER 1 SW has been sent to BSNL CO) the uptime of the 1 GE link of NIT can be increased up to 75% only because of frequent cable cuts, land sliding etc.

The above techno-commercial proposals along with cost involvements may kindly be perused for necessary instruction.

**Encl:** (1) Annexure –I, II & III

(R. N. Paul)

General Manager (CFA)  
West Bengal Telecom Circle

**Copy to:** (1) The CGM/WBTC, BSNL, Kolkata  
(2) The G.M. (STP-Hyderabad)  
(3 Shri.K.Rajashekhar, Addl G.M.(STP-Hyderabad)/Coordinator (NMEICT Project)

WB Circle Office: 1, Council House Street, Kolkata – 700 001 Website: www.wb.bsnl.co.in  
Regd. Office: Sanchar Bhavan, 20, Ashoka Road, New Delhi-110 001  
Corporate Office : B-148, Statesman House, Barakhamba Road, New Delhi-110 001 Website: www.bsnl.co.in

Annexure-I

LINE DIAGRAM OF STM-16 MADM

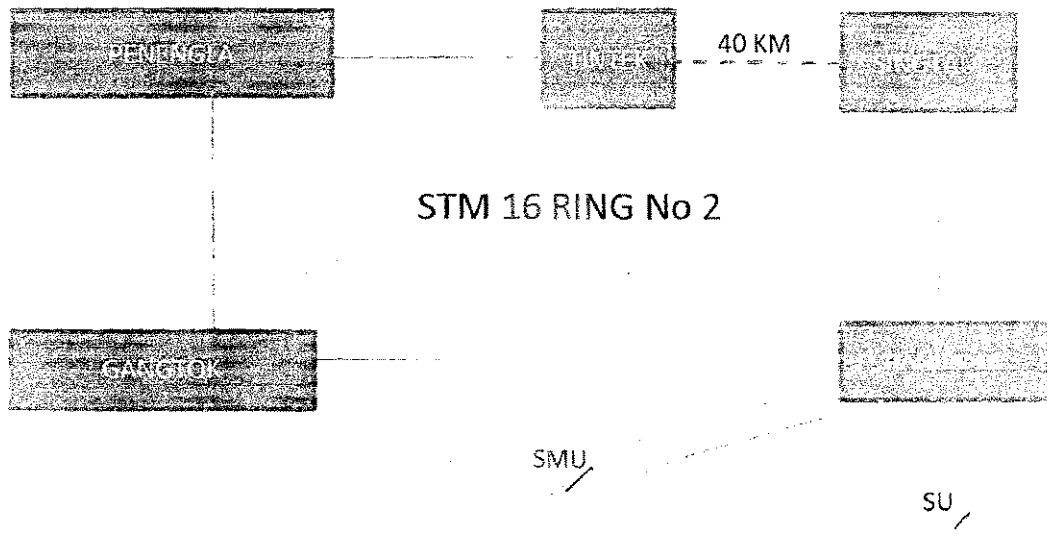
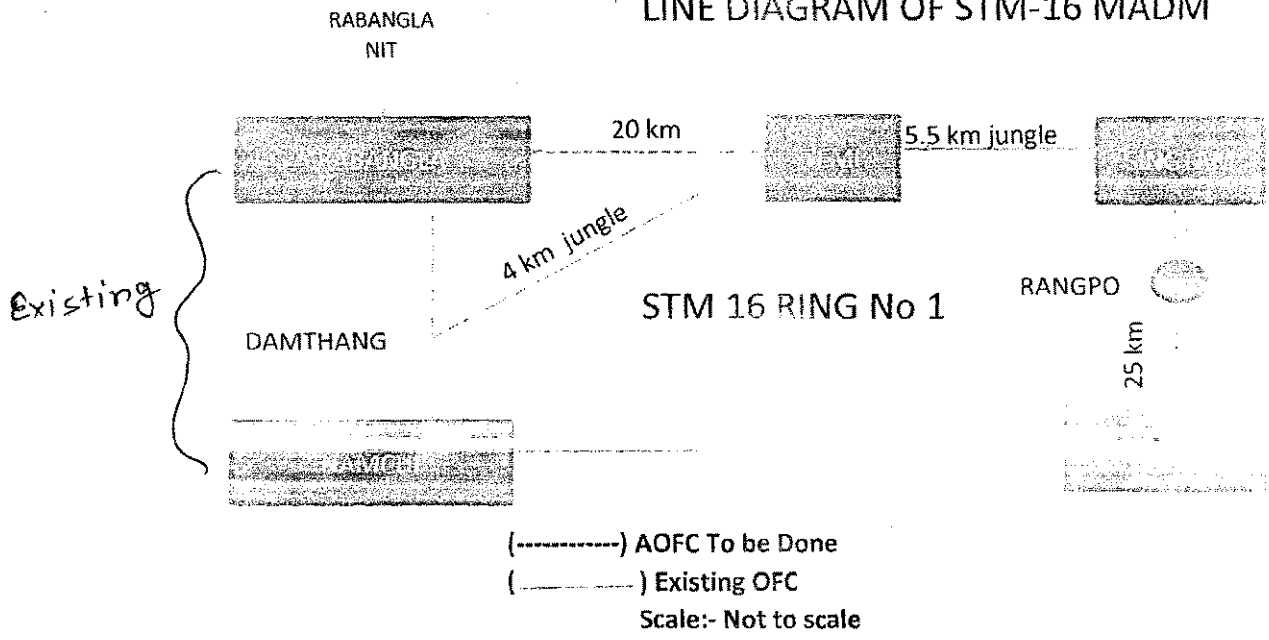

*Wahed*  
21/1/14  
Dy. General Manager  
NPD -Transmission  
WBTC, Kolkata 700001

**BHARAT SANCHAR NIGAM LIMITED**

O/o THE CHIEF GENERAL MANAGER,TELECOM  
West Bengal Telecom, KOLKATA-700001

**PROJECT ESTIMATE FOR: Rabangala TE -Temi TE for NIC, 12 AOFC SCHEME**

SUMMARY OF EXPENDITURE

ITEM	CASH	STORE	OVERHEAD	STM-16	TOTAL
LAND	0	0	0		0
BUILDING	0	0	0		0
E.I.	0	0	0		0
CABLE	2487067	2134681	0		4621748
A & P	195691	0	0	5508579	5704270
M.VEHICLE	989211	0	0		989211
D & E	1022820	0	0		1022820
<b>TOTAL</b>	<b>4694789</b>	<b>2134681</b>	<b>0</b>		<b>12338049</b>
SAY				5508579	12338000
<b>TOTAL CASH (IN LAKH) SAY</b>					<b>123.380</b>

**PROJECT ESTIMATE FOR:- Namthang TE -Rangpo TE for NIC, 12 AOFC SCHEME**

SUMMARY OF EXPENDITURE

ITEM	CASH	STORE	OVERHEAD	STM-16	TOTAL
LAND	0	0	0		0
BUILDING	0	0	0		0
E.I.	0	0	0		0
CABLE	3099660	3100170	0		6199830
A & P	195691	0	0	5508579	5704270
M.VEHICLE	989211	0	0		989211
D & E	1022820	0	0		1022820
<b>TOTAL</b>	<b>5307382</b>	<b>3100170</b>	<b>0</b>		<b>13916131</b>
SAY				5508579	13916000
<b>TOTAL CASH (IN LAKH) SAY</b>					<b>139.100</b>

SUMMARY OF EXPENDITURE FOR AOFC TO BE REPLACED IN EXISTING ROUTE

ITEM	CASH	STORE	OVERHEAD	STM-16	TOTAL
LAND	0	0	0		0
BUILDING	0	0	0		0
E.I.	0	0	0		0
CABLE	1432867	1471904	0		2904771
<b>TOTAL</b>		<b>0</b>	<b>0</b>		<b>2904771</b>
Total cash (in lakh) say					29.047

*[Signature]*  
Dy. General Manager  
NPD -Transmission  
WBTC, Kolkata-700001

4

**Annexure- II**

FINAL 12F AOFC

**Route :---RabanlaTE-Temi TE, Aerial OFC Scheme**

TOTAL ROUTE KM = 20.1 KM  
 TOTAL LENGTH OF CABLE = 22.1 KM  
 TRENCH TO BE DONE 0 KM

**COST OF CABLE LAYING**

Sl. No.	NAMES OF THE ITEMS	Qty.	RATE (₹)	AMOUNT (₹)
1	O.F. Cables 12F (Rate/Km) Aerial *	22.1	54000	1193400
2	Straight Joint Box 12F	14	651	9114
3	Termination Joint Box 12F	2	890	1780
4	T- Joint Box 12F	1	661	661
5	FDF 12F	2	3145	6290
6	Pigtail 10M	24	133	3192
7	Splicing Machine #	1.000	375360	375360
8	Tool Kit	2.000	3750	7500
Total (1 To 8) in Rs				1597297
Cost of installation 5% on item 1-8				79865
c1*d1=g1				1677162

\* TX-09-10/12F AERIAL OFC/2 dt 23.12.09 M/5 Tamilnadu Telecomm. Ltd.

Considering 2% length for cable shrinkage, 0.5% for Jointing & 5% to compensate sagging

Sl. No.	PARTICULARS OF THE ITEMS	Qty.	RATE (₹)	UNIT	AMOUNT (₹)	
					CASH	STORE
1	Cost of Cable & Accessories ( From Table-I)		B/F		1677162	0
2	Pole Fixing cost ( 20 posts per Km) includes A4BC socket & tube fixing and bracket fixing cost	22.1	9420	KM	208182	0
3	Cost of Cable pulling & Erection of cable	22.1	3000	KM	66300	0
4	Cost of Wire Erection	22.1	75.75	KM	1674	0
5	Cost of cable fixing on bracket by Nylon rope	22.1	75.75	KM	1674	0
6	Cost of Binding OF cable	22.1	75.75	KM	1674	0
7	Cost of A4BC pole placed at 50m spacing	442	3650	No.		1613300
8	Cost of RCC work at Poles (1:2:4)	442	1200	No.	530400	
9	Tension Set (12 no /Km)	265	1685.2	No.		446578
10	Suspension Set (3 no /Km)	67	1085.14	No.		72704
11	Demountable Pulley (1 no /5 Kms)	5	419.82	No.		2099
Total					2487066	2134681.48

*[Signature]*  
 21/11/14  
 Dv. General Manager  
 NPD - Transmission  
 WBTC, Kolkata - 700001

**Route :-Namthang-Rangpo , Aerial OFC Scheme**

TOTAL ROUTE KM = 25 KM  
 TOTAL LENGTH OF CABLE = 26.875 KM  
 TRENCH TO BE DONE = 0 KM

**COST OF CABLE LAYING**

Sl. No.	NAMES OF THE ITEMS	Qty.	RATE (₹)	AMOUNT (₹)
1	O.F.. Cables 12F (Rate/Km) Aerial *	26.875	54000	1451250
2	Straight Joint Box 12F	15	651	9765
3	Termination Joint Box 12F	2	890	1780
4	T- Joint Box 12F	1	661	661
5	FDF 12F	2	3145	6290
6	Pigtail 10M	24	133	3192
7	Splicing Machine #	1.000	375360	375360
8	Tool Kit	2.000	3750	7500
Total (1 To 8) in Rs				1855798
Cost of installation 5% on item 1-8				92790
Total				1948588

\* TX-09-10/12F AERIAL OFC/2 dt 23.12.09 M/S Tamilnadu Telecon # ETP/MM/TI/PO/04/08-09/Tirumala dtd. 01.06.09

Considering 2% length for cable shrinkage, 0.5% for Jointing & 5% to compensate sagging

Sl. No.	PARTICULARS OF THE ITEMS	Qty.	RATE (₹)	UNIT	AMOUNT (₹)	
					CASH	STORE
1	Cost of Cable & Accessories ( From Table-I)		B/F		1948588	0
2	Pole Fixing cost ( 20 posts per Km) includes A4BC socket & tube fixing and bracket fixing cost	27	9420	KM	254340	0
3	Cost of Cable pulling & Erection of cable	26.875	3000	KM	80625	0
4	Cost of Wire Erection	26.875	75.75	KM	2036	0
5	Cost of cable fixing on bracket by Nylon rope	26.875	75.75	KM	2036	0
6	Cost of Binding OF cable	26.875	75.75	KM	2036	0
7	Cost of A4BC pole placed at 40m spacing	675	3650	No.		2463750
8	Cost of RCC work at Poles (1:2:4)	675	1200	No.	810000	0
9	Tension Set (12 no /Km)	324	1685.2	No.		546005
10	Suspension Set (3 no /Km)	81	1085.14	No.		87896
11	Demountable Pulley (1 no /5 Kms)	6	419.82	No.		2519
	Total				3099660	3100170.06

*W. Saha*  
 21/11/14  
 Dy. General Manager  
 NPD - Transmission  
 WBTC, Kolkata - 700001



**A & P Calculation for Rabangla- Singtam**

**COST OF TEST GEAR**

Sl.No	NAMES OF THE ITEMS	Qty.	RATE (₹)	AMOUNT (₹)
1	O.T.D.R. ( Mini ) #	1	195691	195691
	Total			195691
	COST OF TEST GEAR FOR THIS ESTIMATE			0

# TX-10-11/T&M/ALT/2 OF M/s Aishwariya Telecom Ltd. Dtd. 03.11.10

**A & P CALCULATION**

Sl.No	ITEM	CASH (₹)	STORE (₹)
A	COST OF EQUIPMENT	0	0
B	COST OF SPARE	0	0
C	COST OF BATTERY & POWER PLANT	0	0
D	COST OF TEST GEAR	0	0
E	COST OF AIR-COOLER	0	0
	TOTAL	0	0
	COST OF INSTALLATION (5% on Cash) ON (A+C+E)	0	0
	TOTAL CASH	0	0

**DIRECTION & EXECUTION**

DIV	MAN - HOURS	QTY.	MAN-MONTH	RATE (₹)	AMOUNT (₹)
CABL E (A)	Route KM :-10/100km	7.2	1.0080	849903	856702
	Route KM :-500/100km	0	0.0000	849903	0
EQUIPMENT (B)	DWDM Tml :-15	0	0.0000	849903	0
	STM-16 Tml/ADM :-12	0			
	STM-1 ADM :-5	0			
	REPEATER:-2	0			
	DIRECTOR'S ESTABLISHMENT(A+B)/3		0.3360	494399	166118
	TOTAL				1022820

**MOTOR VEHICLE**

Sl.No	TYPE OF VEHICLE	QTY	RATE (₹)	AMOUNT (₹)
1	TRUCK(SWARAJ MAZDA)	1	586226	586226
2	M & M DIESEL JEEP	1	402985	402985
3	TOYOTA QUALIS	0	490999	0
	Total			989211

*[Handwritten Signature]*  
 21/1/14  
 Dy. General Manager  
 NTP - Transmission  
 WBPC, -Kolkata - 700001

A & P Calculation for Namthang-Rangpo

**COST OF TEST GEAR**

Sl.No	NAMES OF THE ITEMS	Qty.	RATE (₹)	AMOUNT (₹)
1	O.T.D.R. ( Mini ) #	1	195691	195691
	Total			195691
	COST OF TEST GEAR FOR THIS ESTIMATE			0

# TX-10-11/T&M/ALT/2 OF M/s Aishwariya Telecom Ltd. Dtd. 03.11.10

**A & P CALCULATION**

Sl.No	ITEM	CASH (₹)	STORE (₹)
A	COST OF EQUIPMENT	0	0
B	COST OF SPARE	0	0
C	COST OF BATTERY & POWER PLANT	0	0
D	COST OF TEST GEAR	0	0
E	COST OF AIR COOLER	0	0
	TOTAL	0	0
	COST OF INSTALLATION (5% on Cash) ON (A+C+E)	0	0
	TOTAL CASH	0	0

**DIRECTION & EXECUTION**

DIV	MAN - HOURS	QTY.	MAN-MONTH	RATE (₹)	AMOUNT (₹)
CABL E (A)	Route KM :-10/100Km	7.2	1.0080	849903	856702
	Route KM :-500/100Km	0	0.0000	849903	0
EQUIPMENT (B)	DWDM Tml :-15	0	0.0000	849903	0
	STM-16 Tml/ADM :-12	0			
	STM-1 ADM :-5	0			
	REPEATER:-2	0			
	DIRECTOR'S ESTABLISHMENT(A+B)/3		0.3360	494399	166118
	TOTAL				1022820

**MOTOR VEHICLE**

Sl.No	TYPE OF VEHICLE	QTY	RATE (₹)	AMOUNT (₹)
1	TRUCK(SWARAJ MAZDA)	1	586226	586226
2	M & M DIESEL JEEP	1	402985	402985
3	TOYOTA QUALIS	0	490999	0
	Total			989211

**STM-16 Calculation**

Equipment type	Qty	Rate	Total
STM -16 MADM Type-A	1	418818	418818
STM -16 MADM Type-B	1	428921	428921
STM -16 MADM Type-C	8	410797	3286376
STM-16 Mtce spare 3 Years	3	442350	1327050
Ether net Analyser	3	74260	222780
SDH Analyser with jitter	3	1777738	5333214
		TOTAL	11017159

*[Handwritten Signature]*  
21/11/10  
Dy. General Manager  
NPD -Transmission  
WBTC, -Kolkata -700091

**Annexure III**

**Route :---Existing routes require repair under Aerial OFC Scheme**

TOTAL ROUTE KM = 14 KM  
 TOTAL LENGTH OF CABLE = 16 KM  
 TRENCH TO BE DONE = 0 KM

**COST OF CABLE LAYING**

Sl. No.	NAMES OF THE ITEMS	Qty.	RATE (₹)	AMOUNT (₹)
1	O.F.. Cables 12F (Rate/Km) Aerial *	16	54000	864000
2	Straight Joint Box 12F	10	651	6510
	Total			870510

\* TX-09-10/12F AERIAL OFC/2 dt 23.12.09 M/S Tamilnadu Telecomm. Ltd.

Considering 2% length for cable shrinkage, 0.5% for Jointing & 5% to compensate sagging

Sl. No.	PARTICULARS OF THE ITEMS	Qty.	RATE (₹)	UNIT	AMOUNT (₹)	
					CASH	STORE
1	Cost of Cable & Accessories ( From Table-I)		B/F		870510	0
2	Pole Fixing cost ( 20 posts per Km) includes A4BC socket & tube fixing and bracket fixing cost	16	9420	KM	150720	0
3	Cost of Cable pulling & Erection of cable	16	3000	KM	48000	0
4	Cost of Wire Erection	16	75.75	KM	1212	0
5	Cost of cable fixing on bracket by Nylon rope	16	75.75	KM	1212	0
6	Cost of Binding OF cable	16	75.75	KM	1212	0
7	Cost of A4BC pole placed at 50m spacing	300	3650	No.		1095000
8	Cost of RCC work at Poles (1:2:4)	300	1200	No.	360000	
9	Tension Set (12 no /Km)	192	1685.2	No.		323558
10	Suspension Set (3 no /Km)	48	1085.14	No.		52087
11	Demountable Pulley (1 no /5 Kms)	3	419.82	No.		1259
	Total				1432866	1471904.58

**Existing routes require replacement with Aerial OFC**

sl No	Name of Route	length in km	Replacement to be done
1	Sintam-Rangpo	13	4
2	Namthang -Namchi	32.6	4
3	Namchi-Damthang	14	2
4	Damthang-Rabanla	18.5	1
5	Gantok-Penengla	7.5	1
6	Damthang-Temi-Sintam	17.5	2
	Total	103.1	14

*W. Saha*  
 Dy. General Manager  
 NPD -Transmission  
 WBTC, -Kolkata -700091

49118  
FTS No...../JS(TEL)/2014  
Dated..21/5.....

SPEED POST

Broadband Cell, Corporate Office  
211, Bharat Sanchar Bhavan, Janpath  
New Delhi: 110001  
Ph: 23734094 Fax: 23734284



भारत संचार निगम लिमिटेड  
(भारत सरकार का उपक्रम)  
BHARAT SANCHAR NIGAM LIMITED  
(A Govt. of India Enterprise)

No. 72-07/13-BB Part-I

dated 15-05-2014

To:

✓ The Joint Secretary  
Ministry of HRD  
Shastry Bhavan  
New Delhi.

kind Attn: Sh. Poojeen Prakash.

Sub:-Cost Estimation for formation of OFC ring connectivity to NIT Sikkim for providing reliable 1Gbps connectivity- reg.

Kindly refer to the above subject. BSNL calculated the expenditure involved for formation of OFC ring connectivity to provide reliable 1Gbps connectivity to NIT Sikkim. The expenditure involved for formation of OFC ring to NIT Sikkim comes around Rs 293 Lakhs.

BSNL is ready to provide OFC ring connectivity to NIT Sikkim provided MHRD pays an amount of Rs 293 Lakhs. MHRD may convey the required approval.

(Anil Jain)  
P.G.M.(NWP-BB)

Copy to:  
Dir(CFA) for kind information please.

REGD

wants  
let us prepare  
plan for PAD

Smt. Neelam  
21/5

discuss  
40348/14  
21-5-2014  
21/5/14  
S.O. (GEO)

## Appendix-VII

### Private Universities (Pending to be connected under NKN)

1.	Aryabhata Knowledge University	Bihar	Private University
2.	Dr. C.V. Raman University	Chhattisgarh	Private University
3.	Maharishi University of Management and Technology	Chhattisgarh	Private University
4.	MATS University, Arang Kharora Highway	Chhattisgarh	Private University
5.	Ahmadabad University	Gujarat	Private University
6.	Calorx Teacher's University	Gujarat	Private University
7.	Charotar University of Science & Technology	Gujarat	Private University
8.	Nirma University of Science & Technology	Gujarat	Private University
9.	Apeejay Stya University	Haryana	Private University
10.	ITM University	Haryana	Private University
11.	O.P. Jindal Global University	Haryana	Private University
12.	Arni University, Kathgarh	Himachal Pradesh	Private University
13.	Baddi University of Emerging Sciences & Technology	Himachal Pradesh	Private University
14.	Eternal University	Himachal Pradesh	Private University
15.	Indus International University	Himachal Pradesh	Private University
16.	Maharishi Markandeshwar University	Himachal Pradesh	Private University
17.	Manav Bharti University	Himachal Pradesh	Private University
18.	Shoolini University of Biotechnology and Management Sciences	Himachal Pradesh	Private University
19.	The Institute of Chartered Financial Analysts of India University	Jharkhand	Private University
20.	Alliance University, Bangalore	Karnataka	Private University
21.	CMJ University	Meghalaya	Private University
22.	Techno Global University	Meghalaya	Private University
23.	The Institute of Chartered Financial Analysts of India University	Meghalaya	Private University
24.	University of Science & Technology	Meghalaya	Private University

25.	The Institute of Chartered Financial Analysts of India University	Mizoram	Private University
26.	The Global Open University	Nagaland	Private University
27.	The Institute of Chartered Financial Analysts of India University	Nagaland	Private University
28.	Centurion University of Technology and Management	Orissa	Private University
29.	Chitkara University	Punjab	Private University
30.	Lovely Professional University	Punjab	Private University
31.	Dr. K.N. Modi University	Rajasthan	Private University
32.	Shri Jagdish Prasad Jhabarmal Tibrewala University	Rajasthan	Private University
33.	Shridhar University	Rajasthan	Private University
34.	Eastern Institute for integrated Learning in Management University	Sikkim	Private University
35.	The Institute of Chartered Financial Analysts of India University	Sikkim	Private University
36.	Vinayaka Missions Sikkim University	Sikkim	Private University
37.	Institute of foreign Trade Management University	Uttar Pradesh	Private University
38.	University of Patanjali	Uttarakhand	Private University

## Appendix-VIII

### List of New Universities Taken from UGC

S.No	<b>ANDHRA PRADESH</b>
1.	Damodaram Sanjivayya National Law University, Palace Layout, Pedawaltair, Visakhapatnam – 530 017 (A. P)
2.	Dr. Y.S.R. Horticultural University, PO Box No. 7, Venkataramannagudem, West Godavari District – 536 101, Andhra Pradesh. (State University)*
3.	Dr. N.T.R. University of Health Sciences (Formerly Andhra Pradesh University of Health Sciences), Vijayawada-520 008. (State University)*
4.	Sri Venkateswara Institute of Medical Sciences, Tirupati – 517 507. (State University)
	<b>ARUNACHAL PRADESH</b>
5.	Apex Professional University, Pasighat, District East Siang, Arunachal Pradesh - 791102. (Private University)**
6.	Arunachal University of Studies, NH-52, Namsai, District Namsai – 792 103, Arunachal Pradesh. (Private University)**
7.	Himalayan University, 401, Takar Complex, Naharlagun, Itanagar, Distt – Papumpare – 791110, Arunachal Pradesh. (Private University)**
8.	The Indira Gandhi Technological & Medical Sciences University, Ziro, Arunachal Pradesh. (Private University)**
9.	Venkateshwara Open University, Itanagar, Arunachal Pradesh. (Private University)**
	<b>ASSAM</b>
10.	Assam Down Town University, Sankar Madhab Path, Gandhi Nagar, Panikhaiti, Guwahati – 781 036. (Private University)**
11.	Assam Rajiv Gandhi University of Co-operative Management, Sivasagar, Guwahati, Assam. (State University)*
12.	Assam Science & Technology University, Kahilipara, Guwahati – 19, Assam. (State University)*
13.	Bodoland University, Debragaon, PO Rangalikhata, kokrajhar – 783 370, BTC, Assam. (State University)*
14.	Cotton College State University, Panbazar, Guwahati, Assam. (State University)*
15.	Kumar Bhaskar Varma Sanskrit & ancient Studies University, Nalbari – 781 335, Assam. (State University)*
16.	National Law University and Judicial Academy, NEJOTI Building, B.K. Kakati Road, Bholanath Mandir Path, Ulubari, Guwahati – 781 007, Assam. (State University)*
17.	Srimanta Sankaradeva University of Health Sciences, Narakasur Hilltop, Bhangagarh, Guwahati, Assam. (State University)*
18.	The Assam Kaziranga University, Jorhat, Assam. (Private University)**

	<b>BIHAR</b>
19.	Bihar Agricultural University, Sabour, Bhagalpur – 813210, Bihar. (State University)**
20.	Nalanda University, Rajgir, Dt. Nalanda, Bihar. (Established under Central Act)
	<b>CHHATTISGARH</b>
21.	Bilaspur Vishwavidyalaya, Bilaspur, Chhattisgarh. (State University)*
22.	Chhattisgarh Kamdhenu Vishwavidyalaya, Durg – 491 001, Chhattisgarh. (State University)*
23.	ICFAI University, NH-6, Raipur-Bhilai Road, Gram-Chorha, RI Circle, Ahiwara, Dhamdha, Dist. – Durg, Chhattisgarh. (Private University)
24.	ITM University, PH No. 137, Uparwara, Naya Raipur, Dt. Raipur – 493661, Chhattisgarh. (Private University)**
25.	Kalinga University, Raipur, Chhattisgarh. (Private University)**
26.	AURO University of Hospitality and Management, Surat, Gujarat. (Private University)**
27.	Children’s University, Subhash Chandra Bose Shikshan Sankul, Sector-20, Gandhinagar, Gujarat. (State University)*
28.	C.U. Shah University, Surendranagar-Ahmedabad State Highway, Near Kothariya Village, Wadhwan City – 363030, Dt. Surendranagar, Gujarat. (Private University)**
29.	Indian Institute of Teacher Education, Government College Campus, Near Mahatma Mandir, G-4, Sector-15, Gandhinagar – 382 016, Gujarat. (State University)*
30.	Indus University, Indus Campus, Rancharda, Via-Thaltej, Ahmedabad – 382115, Gujarat. (Private University)**
31.	Maharaja Krishnakumarsinji Bhavnagar University, Bhavnagar- 364 002(State University)
32.	Navrachana University, Vasna-Bhayli Road, Vadodara – 391410, Gujarat (Private University) **
33.	Raksha Shakti University, New Mental Corner, Meghaninagar, Ahmedabad – 380 016, Gujarat. (State University)*
34.	R.K. University, Rajkot-Bhavnagar Highway, Kasturbadham, Rajkot, Gujarat. (Private University)**
35.	Rai University, Ahmedabad, Gujarat. (Private University)**
36.	Swarnim Gujarat Sports University, Sector-19, Punit Van Road, Near – Suvidha Kendra, PTC Building Campus, Gandhinagar – 382 019, Gujarat. (State University)*
37.	UKA Tarsadia University, Maliba Campus, Gopal vidyanagar, Baroli-Mahuva Road, Dist. Surat, Gujarat (Private University)**
38.	Vir Narmad South Gujarat University, Surat-395 007, Gujarat (State University).



<b>HARYANA</b>	
39.	Ansal University, Gurgaon, Haryana. (Private University)**
40.	Baba Mast Nath University, Rohtak, Haryana. (Private University)**
41.	G.D. Goenka University, G.D. Goenka Education City, Gurgaon sohna Road, Gurgaon, Haryana – 122 103. (Private University)**
42.	Jagan Nath University, State Highway 22, Bahadurgarh-Jhajjar Road, Jhajjar – 124 507, Haryana. (Private University)**
43.	K.R. Mangalam University, Sohna Road, Gurgaon, Haryana – 122 103. (Private University)**
44.	Lala Lajpat Rai University of Veterinary & Animal Sciences, Hisar – 125 004 Haryana.* (State University)
45.	Maharishi Markandeshwar University, Sadopur, Dt. Ambala, Haryana. (Private University)**
46.	M.V.N. University, Palwal, Haryana. (Private University)**
47.	National Institute of Food Technology, Entrepreneurship & Management (NIFTEM), Plot No 97, Sector 56, HSIIDC Industrial Estate, Kundli, Dt. Sonapat, Haryana. (Deemed University)
48.	NIILM University, 9 KM Milestone, NH-65, Kaithal – 136 027, Haryana (Private University)**
49.	Shree Guru Gobind Singh Tricentenary University, Farukh Nagar Road, Budhera, Distt. Gurgaon, Haryana. (Private University)**
50.	SRM University, Plot No. 39, Rajiv Gandhi Education City, Delhi-NCR, Sonapat-Kundli Urban Complex, Haryana – 131 029. (Private University)**
51.	YMCA University of Science & Technology, Faridabad – 121 006, Haryana (State University)*
<b>HIMACHAL PRADESH</b>	
52.	A.P.G.(Akh Prakash Goyal) University, Shimla, Himachal Pradesh. (Private University)**
53.	Bahra University, VPO – Wagnaghat, Tehsil – Kandaghat, Distt.- Solan, Himachal Pradesh (Private University)**
54.	Career Point University, Hamirpur, Himachal Pradesh. (Private University)**
55.	Chaudhary Sarwan Kumar Himachal Pradesh Krishi Vishvavidyalaya, Palampur-176 062 (State University).
56.	Himachal Pradesh Technical University, Hamirpur, Himachal Pradesh (State University)
57.	ICFAI University, HIMUDA Education Hub, Kalujhinda, PO Mandhala, Via Barotiwala, Baddi, Solan Distt., Himachal Pradesh – 174 103. (Private University)
58.	I.E.C. (India Education Centre) University, Baddi, Solan, Himachal Pradesh. (Private University)**
59.	Maharaja Agrasen University, Atal Shiksha Kunj, Distt – Solan – 174 103, Himachal Pradesh. (Private University)**
60.	Sri Sai University, Palampur, Himachal Pradesh. (Private University)**

<b>JAMMU &amp; KASHMIR</b>	
61.	Sher-e-Kashmir University of Agricultural Science & Technology, Chatha, Jammu - 180009 (State University).
62.	Jharkhand Rai University, Jharkhand. (Private University)**
63.	National University of Study & Research in Law, Polytechnic campus, BIT Mesra, Ranchi – 835 217 Jharkhand.* (State University)
64.	Sai Nath University, Ranchi, Jharkhand. (Private University)**
<b>KARNATAKA</b>	
65.	Azim Premji University, 134, Doddakanneli, Next to Wipro Corporate Office, Sarjapur Road, Bangalore, Karnataka.(Private University)**
66.	Karnataka Sanskrit University, Bangalore, Karnataka (State University)*
67.	Karnataka Folklore University, 2/106, KASSIA Building, 3 <sup>rd</sup> Floor, 17 <sup>th</sup> Cross, Magadi Chord Road, Vijayanagar, Bangalore – 460 040, Karnataka. (State University)*
68.	KSGH Music and Performing Arts University, LJB Road, Near Ashoka Circle, Lakshmipuram, Mysore – 570 004, Karnataka (State University)*
69.	M.S. Ramaiah University of Applied Sciences, Administrative Block, New BEL Road, MSRIT Post, Bangalore – 560 054, Karnataka. (Private University)**
70.	PES University, 100 Feet Ring Road , BSK III Stage, Bangalore – 560 085 (Karnataka) (Private University)**
71.	Presidency University (Karnataka), Dibbur & Igalpur Village, Hesaraghatta Hobli, Bangalore (Karnataka). (Private University)**
72.	Rani Channamma University, Vidyasangama, N.G. – 4, P.B. Highway, Belagavi – 591 156 Karnataka * (State University)
73.	Reva University, Kattigenhalli, Yelhanka, Bangalore – 560 064. (Private University)**
74.	Vijayanagara Sri Krishnadevaraya University, Jnana Sagara Campus, Vinayaka Nagar, Contonment, Bellary – 583 104 Karnataka.* (State University)
<b>KERALA</b>	
75.	Thunchath Ezhuthachan Malayalam University, Mohan Vilas, Pukayil PO, Tirur, Malappuram Distt., Kerala – 676 107. (State University)*
<b>MADHYA PRADESH</b>	
76.	A.K.S. University, Satna, Madhya Pradesh. (Private University)**
77.	Atal Bihari Vajpai Hindi Vishwavidyalaya, M.P. Bhoj (Open) University Campus, Kolar Marg, Bhopal – 462016, Madhya Pradesh. (State University)*
78.	Amity University, Maharajpura Dang, Gwalior, Madhya Pradesh. (Private University)**
79.	AISECT University, Bhopal-Chiklod Road, Near Bangrasia Chouraha, Bhopal, Madhya Pradesh (Private University)**
80.	ITM University, ITM Campus, Opp. Sithouli Rly. Station, NH – 75, Jhansi Road, Gwalior-474 001, Madhya Pradesh. (Private University)**

81.	Jagran Lakecity University, Raja Bhoj Marg, Chunabhati, Kolar Road, Bhopal – 462 016, Madhya Pradesh. (Private University)**
82.	Oriental University, Opp. Rewati Range Gate No. 1, Sanwer Road, PO Box No. 311, Vijay Nagar Post Office, Indore – 452 010, Madhya Pradesh. (Private University)**
83.	Pandit Dwarka Prasad Mishra Indian Institute of Information Technology, Design & Manufacturing, IT Bhavan, Government Engineering College, Jabalpur, Madhya Pradesh. (Deemed University).
84.	People's University, Bhanpur, Bhopal – 462 037. (Private University)
85.	Raja Mansingh Tomar Music & Arts University, Mahadaji Chok, achaleshwar Marg, Gwalior – 474 009, Madhya Pradesh. (State University)*
86.	RKDF University, By-Pass Road, Near RGPC Campus, Bhopal, Madhya Pradesh. (Private University)
87.	Rajmata Vijayaraje Scindia Krishi Vishwavidyalaya, Opp. Mela Ground, Race Course Road, Gwalior – 474 002, Madhya Pradesh. (State University)*
88.	Swami Vivekananda University, Sagar, Madhya Pradesh. (Private University)**
89.	Techno Global University, Lateri Road, Sironj (Near Gosala), Dist – Vidisha, Madhya Pradesh – 464 228. (Private University)**
<b>MAHARASHTRA</b>	
90.	Gondwana University, MIDC Road Complex, Gadchiroli – 422 605, Maharashtra. (State University)*
<b>MEGHALAYA</b>	
91.	Mahatma Gandhi University, P.O. Araimile, Matchakolgre, Tura, West Garo Hills, Meghalaya (Private University)**
92.	University of Technology & Management, Shillong, Meghalaya (Private University)**
93.	William Carey University, Zoram Villa, Bomfylde Road, Shillong – 793 001, Meghalaya. (Private University)**
<b>ORISSA</b>	
94.	Sri Sri University, Bhubaneswar, Orissa. (Private University)**
95.	Xavier University, Xavier Square, Bhubaneswar, Odisha. (Private University)**
<b>PUNJAB</b>	
96.	Adesh University, NH-7, Barnala Road, Bathinda, Punjab. (Private University)**
97.	Chandigarh University, Gharuan, Mohali – 140413, Punjab. (Private University)**
98.	D.A.V. University, Jalandhar-Pathankot National Highway-44, Village-Sarmastpur, Jalandhar, Punjab. (Private University)**
99.	Desh Bhagat University, Amlon Road, Mandi Gobindgarh, Punjab. (Private University)**

100.	Guru Kashi University, Talwandi Sabo, Dt. Bhatinda, Punjab. (Private University)**
101.	Guru Ravidas Ayurved University, Jodhmal, Hoshiarpur, Punjab. (State University)*
102.	Sri Guru Granth Sahib World University, Sri Lalgidhar Niwas, Plot No. 6, Madhya Marg, Sector – 27-B, Fatehgarh Sahib, Chandigarh (Private University)**
	<b>RAJASTHAN</b>
103.	Career Point University, Kota, Rajasthan. (Private University)**
104.	Geetanjali University, Udaipur, Rajasthan. (Private University)**
105.	Haridev Joshi University of Journalism & Mass Communication, Information Centre Complex, Sawai Ram Singh Road, Jaipur – 302 004, Rajasthan. (State University)*
106.	Homoeopathy University, Saipura, Sanganer, Jaipur – 302 029, Rajasthan. (Private University)**
107.	ICFAI University, Khasra No. 505/1, Village-Jamdoli, Agra Road, Jaipur – 302 031, Rajasthan. (Private University)
108.	J.K. Lakshmi Pat University, Laliya Ka Vas, PO Mahapura, Ajmer Road, Jaipur – 302 026, Rajasthan. (Private University)**
109.	J.E.C.R.C. University, Jaipur, Rajasthan. (Private University)**
110.	Maharaja Ganga Singh University, National Highway No. – 15, Jaisalmer Road, Bikaner, Rajasthan.* (formal name - University of Bikaner, 23, Civil Lines, Bikaner ) (State University)
111.	Mahatma Gandhi University of Medical Sciences & Technology, RIICO Institutional Area, Sitapur, Tonk Road, Jaipur – 302 022, (Private University)**
112.	Maharaj Vinayak Global University, Jaipur, Rajasthan. (Private University)**
113.	Manipal University, Vatika Infotech City, Near GVK Toll Plaza, Jaipur ajmer Experss Way, Post – Thikaria, Jaipur – 302 026, Rajasthan. (Private University)**
114.	OPJS University, Rawatsar, Kunjila, Tehsil-Rajgarh, Distt. – Churu, Rajasthan. (Private University)**
115.	Poornima University, Ramchandrapura, Sitapura Extension, Jaipur, Rajasthan. (Private University)**
116.	Pratap University, Sunderpura (Chandwaji), Amer, Delhi-Mumbai Highway, Jaipur, Rajasthan (Private University)
117.	Raffles University, Japanese Zone, National Highway 8, Neemrana-201 705, Rajasthan. (Private University)**
118.	Sangam University, Bhilwara, Rajasthan. (Private University)**
119.	Sardar Patel University of Police, Security & Criminal Justice, Jodhpur, Rajasthan. (State University)*

120.	Sunrise University, Bagad Rajput, Tech. Ramgarh, Alwar, Rajasthan (Private University)**
121.	Tantia University, Hanumangarh Road, Sri Ganganagar – 335 002, Rajasthan (Private University)**
122.	University of Engineering & Management, Jaipur, Rajasthan. (Private University)**
123.	Vivekananda Global University, Sector-36, NRI Road, Sisyawas, Jagatpura, Jaipur – 303012, Rajasthan. (Private University)**
<b>TAMILNADU</b>	
124.	Tamilnadu Fisheries University, First Linebeach Road, Nagapattinam – 611001, Tamilnadu. (State University)*
125.	Tamilnadu National Law School, Navalur Kuttapattu, Srirangam Taluk, Tiruchirapalli – 620 009, Tamilnadu. (State University)*
<b>UTTAR PRADESH</b>	
126.	Babu Banarasi Das University, 55, Babu Banarasi Das Nagar, Lucknow, Uttar Pradesh.(Private University)**
127.	Galgotias University, 1, Knowledge Park, Phase-II Greater Noida – 201 306, Uttar Pradesh. (Private University)**
128.	Khwaja Moinuddin Chishti Urdu, Arabi~Farsi University, 619, Indira Bhavan, Lucknow, Uttar Pradesh (State University) *
129.	Monad University, Kasmabad, PO-Pilkhua, Dt. Hapur, Uttar Pradesh. (Private University)**
130.	Mahamaya Technical University, C-22, Sector-62, Noida, G.B. Nagar, Uttar Pradesh.-201 301 (State University)*
131.	Noida International University 309 Jaipuria Plaza, Sector – 26, Noida (U.P) (Private University)**
132.	Rajiv Gandhi National Aviation University, Fursatganj, Dt. Raebareli, Uttar Pradesh (Central University)
133.	Shiv Nadar University, Dadri, Gautham Budh Nagar, Uttar Pradesh (Private University)**
134.	Shobhit University, Adarsh Institutional Area, Babu Vijendra Marg, Gangoh, Distt. – Saharanpur – 247 341, (Uttar Pradesh) (Private University)**
135.	Shri Ramswaroop Memorial University, Hadauri, Deva-Lucknow Road, Dt. Barabanki, Uttar Pradesh. (Private University)**
136.	Shri Venkateshwara University, NH-24, Rajabpur, Gajraula, J.P. Nagar, Uttar Pradesh (Private University)**
137.	The Glocal University, Ali Akbarpur, Mizapur Pole, Tehsil – Behat, Saharanpur – 247001, Uttar Pradesh. (Private University)**
138.	Uttar Pradesh Viklang Uddhar Dr. Shakuntala Misra University, Mohan Road, Lucknow, Uttar Pradesh.* (State University)
<b>UTTARAKHAND</b>	
139.	DIT University, Mussoorie Diversion Road, Dehradun – 248 009, Uttarakhand. (Private University)

140.	Graphic Era Parvatiya Vishwavidyalaya, 600, Bell Road, Clement Town, Dehradun – 248 002, Uttarakhand. (Private University)**
141.	Himgiri Zee University, Sheeshambada, PO-Sherpur, Via-Sahaspur, Dehradun-248197, Uttarakhand. (Private University)
142.	IMS Unison University, Makkawala Greens, Mussoorie Diversion Road, Dehradun – 248 009, Uttarakhand. (Private University)**
143.	Sri Dev Suman Uttarakhand Vishwavidyalay, Badshahithaul, Tehri Garhwal, Uttarakhand-249199. (State University)*
144.	Swami Rama Himalayan University, Swami Ram Nagar, Jolly Grant, PO – Doiwala, Dehradun, Uttarakhand. (Private University)**
145.	Uttarakhand Ayurved University, 7-A, Pleasant Valley, Rajpur Road, Dehradun – 248 009, Uttarakhand. (State University)*
146.	Uttarakhand Open University, Near Transport Nagar, Teenpani By-Pass Road, PO – Industrial Estate, Haldwani-263 139 (Nainital), Uttarakhand. (State University)*
147.	Uttaranchal University, Arcadia Grant, PO Chandanwari, Premnagar, Dehradun – 248 007, Uttarakhand. (Private University)**
<b>WEST BENGAL</b>	
148.	Kazi Nazrul University, Old ADDA Office Building (behind Asansol Girls College), PO – Asansol-713304, Dist – Burdwan, West Bengal. (State University)*
149.	Presidency University, 86/1 College Street, Kolkata – 700 073, West Bengal (State University)
150.	Techno India University, EM – 4, Sector-V, Salt Lake, Kolkata – 700 091, West Bengal. (Private University)**
<b>NCT OF DELHI</b>	
151.	Indira Gandhi Delhi Technical University for Women, Kashmere Gate, Delhi – 110 006. (State University)*

## Appendix - IX.

### List of Centrally Funded Institutions

S. No.	List of pending Centrally Funded Institutions of MHRD
1.	National Institute of Industrial Engineering (NITIE), Mumbai
2.	University Grants Commission
3.	Indian Council of Historical Research
4.	Indian Council of Philosophical Research
5.	National Council of Rural Institutes
6.	Board of Apprenticeship Training, Mumbai
7.	Board of Apprenticeship Training, Kolkata
8.	Board of Apprenticeship Training, Kanpur
9.	Board of Apprenticeship Training, Chennai
10.	All India Council for Technical Education (AICTE)
11.	Kendriya Hindi Sansthan
12.	National Council for Promotion of Urdu Language
13.	National Council for Promotion of Sindhi Language
14.	National Council for Promotion of Hindi Language

संयुक्त सचिव एवं मिशन निदेशक (NMEICT)  
भारत सरकार  
मानव संसाधन विकास मंत्रालय  
उच्च शिक्षा विभाग  
Joint Secretary & Mission Director (NMEICT)  
Government of India  
Ministry of Human Resource Development  
Department of Higher Education

प्रवीण प्रकाश, आई.ए.एस.  
Praveen Prakash, I.A.S.

सत्यमेव जयते

Date: 19.05.2014

**Subject: Office Space for Mission Secretariat of NMEICT.**

Dear Mr. Mangu Singh,

The National Mission on Education through ICT (NMEICT) is a landmark initiative of the Ministry of Human Resource Development (MHRD) to address all the education and learning related needs of students, teachers and lifelong learners.

Providing of connectivity to all Colleges and Universities is one of the major components of the Mission. For this purpose, we have to regularly interact with NKN & National Data Centre (NDC) of NIC, which is located at DMRC Building in the Shastri Park.

The Mission Secretariat of NMEICT currently operating from various locations in the capital also faces space constraints for its effective functioning, besides this shall facilitate to optimally utilize the resources of the Bureau We are in need of Office Space of around 7,000 sq feet. It is requested that one of the floors be leased to the Mission Secretariat of NMEICT. The applicable lease rent shall be paid by us.

In this context, I would request you to kindly give me appointment on Friday 23<sup>rd</sup> May, 2014 between 3 to 5 pm in your office.

  
(Praveen Prakash)

JS (TEL) & Mission Director (NMEICT)

To,

Sh. Mangu Singh  
Managing Director,  
Delhi Metro Rail Corporation (DMRC) Ltd.  
Metro Bhawan  
Fire Brigade Lane, Barakhamba Road,  
New Delhi - 110001, India





# दिल्ली मेट्रो रेल कॉर्पोरेशन लि० DELHI METRO RAIL CORPORATION LTD.

(भारत सरकार एवं दिल्ली सरकार का संयुक्त उपक्रम)  
(A JOINT VENTURE OF GOVERNMENT OF INDIA AND GOVT. OF DELHI)

DMRC/PD/L-1/ITP/780

27.5.2014

To  
JS (TEL) & Mission Director (NMEICT)  
Department of Higher Education  
Ministry of Human Resource Development  
Room No. 122B, "C" Wing, Shastri Bhawan  
New Delhi-110001

Sir,

**Sub: Office Space for Mission Secretariat of NMEICT**  
**Ref: Letter dt 19.5.2014**

With reference to your letter dt. 19.5.2014, it is to intimate that the following areas are available for leasing in IT Park:-

S. No.	Block	Floor	Area
1.	3	Ground Floor	1245 sqm
2.	3	Ground Floor	1174 sqm
3.	1	5 <sup>th</sup> floor	526 sqm

It is requested that confirmation of location from the options mentioned above may kindly be sent, so that process for negotiating lease rent & terms and conditions can be initiated.

Yours faithfully

*(Signature)*  
(Ajay Sharma)  
Chief Engineer/PD

27.5.14

प्रवीण प्रकाश, आई.ए.एस.  
Praveen Prakash, I.A.S.



संयुक्त सचिव एवं मिशन निदेशक (NMEICT)  
भारत सरकार  
मानव संसाधन विकास मंत्रालय  
उच्च शिक्षा विभाग  
Joint Secretary & Mission Director (NMEICT)  
Government of India  
Ministry of Human Resource Development  
Department of Higher Education

F.No. 8-42/2013-TEL

Date: 04.06.2014

**Sub: Space for the office of Mission Secretariat of NMEICT.**

Dear Mr. Ajay Sharma,

With reference to your office letter No. DMRC/PD/L-1/ITP/780 dated 27.05.2014, this is to confirm that the site inspection of the various locations from the options available of DMRC buildings at Shastri Park was undertaken by the undersigned.

Since in NMEICT we have to regularly interact with NKN and National Data Center of NIC, which are located at the adjacent block at DMRC Building at Shastri Park, we hereby confirm that the following location has been found to be suitable as per our requirements:

Block	Floor	Area	Remarks
1	5 <sup>th</sup> Floor	526 sqm	DITP B Wing Side, DMRC IT Park, Shastri Park, Delhi 110053 [Previously occupied by Apollo Munich].

It is requested that the process for the negotiating lease rent and other terms & conditions may be finalized by 12<sup>th</sup> June, 2014 to enable us to initiate further appropriate action in the matter.

With regards,

  
(Praveen Prakash)

JS (TEL) & Mission Director (NMEICT)

To,

Mr. Ajay Sharma,  
Chief Engineer/PD  
Delhi Metro Rail Corporation Ltd.,  
Metro Bhawan, Fire Brigade Lane,  
Barakhamba Road, New Delhi-110 001

**Table Agenda**  
**for**  
**Project Approval Board (PAB)**  
**Meeting**

**on**

**26<sup>th</sup> June, 2014**

**at**

**Conference Room,  
3<sup>rd</sup> Floor, Block No. 3,  
NKN,  
DMRC Building,  
Shastri Park, New Delhi 110 053.**

**TABLE AGENDA 28<sup>th</sup> MEETING OF PROJECT APPROVAL BOARD OF NATIONAL MISSION ON EDUCATION THROUGH INFORMATION AND COMMUNICATION TECHNOLOGY TO BE HELD ON 26<sup>th</sup> JUNE, 2014 AT 15:00 HRS AT CONFERENCE ROOM, 3<sup>rd</sup> FLOOR, BLOCK NO. 3, NKN, DMRC BUILDING, SHASTRI PARK, NEW DELHI-110 053.**

<b>Agenda Item No.</b>	<b>Subject</b>	<b>Page No.</b>
1.	DMRC Letter No. DMRC/PD DATED	130
2.	Development of National, Digital Library of India, Towards Building a National Asset.  PI: Prof Partha P Chakrabarti Director, IIT Kharagpur.	131-135
3.	i) Enhancement, Maintenance and Support of the HRD Ministry Website and  ii) Design and Development of the Website of Minister of Human Resource Development;  PI: Ms. V. Rajeswari, Sr. Technical Director, National Informatics Center (NIC) & Mr. P.K. Saha, Deputy Secretary,	136-150
4.	Providing Wi-Fi at the Department of Higher Education, Ministry of HRD.	151-152
5.	An Open Source Indian MOOCs Platform PI: Prof. Deepak B Phatak	153-157
Appendix		
Appendix- XIV	Proposal Dig Library IITKGP	158-174
Appendix- XIV	Detailed Project Reports (DPR) –MOOCs Platform	175-188





**दिल्ली मेट्रो रेल कॉर्पोरेशन लि०**  
**DELHI METRO RAIL CORPORATION LTD.**  
(भारत सरकार एवं दिल्ली सरकार का संयुक्त उपक्रम)  
(A JOINT VENTURE OF GOVERNMENT OF INDIA AND GOVT. OF DELHI)

DMRC/PD/L1/ITP-B1/DITP-5D/780-Vol-I

25/06/2014

**Shri Praveen Prakash, IAS,**  
Joint Secretary (TEL) & Mission Director (NMEICT),  
Government of India,  
Ministry of Human Resource Development,  
Department of Higher Education,  
Room No.122-B, C-Wing,  
Shastri Bhawan, New Delhi.  
Fax No. 23385327

**Sub: - Renting of space in Block-1 of Delhi IT Park at Shastri Park.**  
Ref: - Your letter No. Nil dated 11/06/2014.

Dear Sir,

In reference to above, office space at 5<sup>th</sup> floor of Block-1 at Delhi IT Park, Shastri Park is offered to you with following terms and conditions. These terms are subject to formal approval by competent authority.

- |                            |   |  |
|----------------------------|---|--|
| 1. Floor offered to        | : | 5 <sup>th</sup> Floor of Block-1, Delhi IT Park, Shastri Park.   |
| 2. Area approx.            | : | 526 Sq.m (5662 Sqft), super built up   |
| 3. Period of license       | : | 10 Years.  |
| 4. Rentals/License fees    | : | Rs.900/-Per Sq.m per Month plus Service Tax.   |
| 5. Maintenance Charges     | : | Rs.120/-per Sq.m per Month plus Service Tax.   |
| 6. Water Charges           | : | Rs.4.5/- per Sqm per month plus service tax.<br>Rates for water charges shall be fixed by DMRC & be revised from time to time. |
| 7. Escalation              | : | 15% every three years on license fees and security deposit & 5% every year on Maintenance charges.                             |
| 8. Security Deposit        | : | One year rentals   |
| 9. Payment                 | : | Rentals & Maintenance charges to be paid in advance by 10 <sup>th</sup> of each quarter.                                       |
| 10. Fit out period allowed | : | 45 days from date of handing over.   |
| 11. Electricity            | : | Required power supply shall be made available at one point. Power consumption shall be charged on standard DERC rates.         |

It is requested to convey your acceptance of above at the earliest. Further details can be discussed at your convenience.

Thanking you

Yours sincerely

  
(Shishir Tyagi)  
Dy. Chief Engineer/PD

## Table Agenda No: 1

<b>Proposal</b>	<b>:</b> <b>Development of National, Digital Library of India, Towards Building a National Asset.</b>
<b>PI</b>	<b>:</b> <b>Prof Partha P Chakrabarti Director, IIT Kharagpur,</b> <a href="mailto:director@iitkgp.ernet.in">director@iitkgp.ernet.in</a> , <a href="mailto:ppchak@cse.iitkgp.ernet.in">ppchak@cse.iitkgp.ernet.in</a>
<b>Co-PIs</b>	<b>:</b> <b>Dr B Sutradhar, Librarian, IIT Kharagpur, Kharagpur 721302 India</b> <b>Email: <a href="mailto:bsutra@library.iitkgp.ernet.in">bsutra@library.iitkgp.ernet.in</a></b>
<b>Institute</b>	<b>:</b> <b>IIT Kharagpur</b>

### Background Note:

A brief outline on the back ground, objectives, structure and methodology for the National Digital Library and proposes a Pilot project under the NMEICT programme of MHRD to initiate this activity through a consortium of CFTIs, colleges and schools is presented. The Pilot Phase of the project is expected to develop the overall frame work that can subsequently be refined and extended in two subsequent phases all over the country. In addition the Pilot Phase will help collate (and if needed generate) large number of e-contents for school, college and higher category students with special emphasis on the e-learning, virtual library and technology enhanced learning design covering the needs of learners with differing abilities, expectations and socio cultural background. This project will also enable some key national knowledge discovery and immersive learning platforms built around this Digital Library. It will also encourage entrepreneurial development of tools around this platform. In its final contour the system may serve as a pan-India virtual teaching- learning-evaluation-knowledge discovery and innovation platform, a key national asset. The users are at present facing problem to access those e-resources due to several reasons including:

- i) Users have to visit individual website to access e-resources
- ii) Users need to learn retrieval techniques / search techniques separately as different Digital Library(DL) follows different DL software (and DL software employs different text retrieval engines (like Solr, MGPP, Lucene, Zebraetc)
- iii) Few e-Learning environments are available for the students and teachers that access information from all available sources

- iv) Non integration of learner-learner, teacher-teacher and teacher-learner communication tools within learning environment
- v) Learning resources are generally outside the integrated learning environment
- vi) Distance mode of learning in India is helping only to increase learner-base not the knowledgebase.
- vii) In most of the cases user interfaces are not interactive, collaborative and participative.
- viii) No Single window search facility is not available of all resources.
- ix) Few mechanisms are available for differently abled learners.
- x) Tools for knowledge discovery that enable integration and collation of available knowledge from various repositories to create acknowledge archive on various subjects is not yet available for scholars

Considering the above issues, there is therefore need to develop a National Digital Library in India to collect, preserve and disseminate all the intellectual output of our country to provide online access to school level to post graduate level including technical education. Central Library of IIT Kharagpur has already developed an inter operable Institutional Digital Repository to preserve the intellectual output produced by the faculty members, students and staff. This expertise can be utilized to design and development of National Digital Library in India.

**Objectives:**

- i) To develop National Learning Object Repository spanning school level to PG level including technical education.
- ii) To build a national learning object repository providing free access to quality e-contents and education to all students at primary, secondary and higher education level.
- iii) Enable improvement in quality of learning by implementing various learning objects.
- iv) Access to near real-time and better quality data for decision support.
- v) Design and development of OAI-PMH Server for metadata harvesting at National Level.

- vi) Initiative to make each existing operational Digital Library OAI/PMH-compliant.
- vii) Contents from each digital repository of India will be harvested with the help of OAI-PMH protocol. Harvested digital contents will be indexed in one Central server for online access
- viii) Born digital in-house resources produced by the faculty members, staff, and students to be collected and uploaded into the National Digital Library Server
- ix) To provide online document deliver services of licensed e-resources across the country
- x) To provide Cloud based solutions and support to university and college libraries for running their DL server in 24 X 7 mode
- xi) Design and Development of a web-scale Discovery Server which will provide single window search facility of all e-resources collected from different Institutions, Universities and different Digital Library projects and all open access learning resources
- xii) Unicode-compliant multi lingual environment will be created for storing, processing and retrieving of indigenous digital contents with regional language based interfaces
- xiii) Collaborative Learning Management Tools and Technology will be implemented
- xiv) Virtual e-Learning will be implemented to help the remote access at National Level
- xv) To provide infrastructural support to school and college libraries to access the learning materials from NDL
- xvi) To have special verticals for various levels including schools, sciences, arts, commerce, law, economics & social sciences, medicine
- xvii) To develop Immersive Learning Platforms to study subjects ranging from school geography, history and science to advanced technical topics in engineering, medicine, architecture and social sciences
- xviii) To enable and develop several Digital Knowledge Platforms for several key national research initiatives like Himalayas, Ganga, etc to integrate knowledge from various sources and connecting them to the National GIS programmes and their platforms.



### **Process / Major Gaps:**

- i) Total number of classrooms in India- 4 Mn, out of which 0.15 Mn is having some or little facility of ICT and e-contents.
- ii) 95% of the colleges still do not have basic amenities [ Source : Rothin Bhattacharya ]
- iii) Many remote colleges do not have e-Learning content or access nor infrastructure
- iv) Lack of single point of reference for integrated digital content for variety of user groups.
- v) No specific ICT tools and e-contents present for differently abled students in most of the schools, colleges and universities.
- vi) As there is a technology shift i.e. from PC to Tables to Mobile devices, henceforth many contents needs to be converted to suitable format. Like EPUB data is more suitable for tablets to access rather than PDF data file.

### **Possible ways to address the above Gap**

- i) ICT and e-contents @Schools, @Universities, @Colleges will help us to minimize this gap.
- ii) Collaborative e-Learning Frame work needs to be implemented where all the stakeholders' works together in the learning phase.
- iii) Self Based Learning Framework (SBLF) will next most important learning phenomena therefore digital Library access is required for self based learning
- iv) Tablet & mobile devices will also play a major role in SBLF.
- v) New apps will be designed and develop for accessing e-contents from proposed National Digital Library
- vi) Many Entrepreneurs will participate in this project in future to design and develop application software for providing value added services.

### **Methodology:**

- i) Identification of learning objects on global scale;
- ii) Design of selection parameters (initially emphasis would be give non open learning objects)

- iii) Development of a composite software architecture (digital archive to store learning objects, Learning Content Management System (LCMS) to provide teaching-learning-evaluation functionalities, Search and retrieval layer with Indic-script-enabled user interface).
- iv) Selection of learning objects and incorporation of metadata (SCORM-compliant domain-specific metadata schema will be used for the purpose);
- v) Testing and debugging of NDL.

### **Target Beneficiaries:**

- vi) School Library users
- vii) College Library Users
- viii) University Library Users
- ix) Higher technical education Library users
- x) Legal Community Users (initially academic, then Professional)

### **Physical Targets:**

The whole project will be divided into 3 phases. Initially a Pilot Project is proposed.

**Phase-1: Pilot Project initiated by IIT Kharagpur in collaboration with some other selected CFTIs** including IITs, NITs and Schools libraries, Legal Libraries and INFLIBNET (This Pilot project is estimated to cost Rs 40 crore to 100 crore depending on scope and span. The Pilot project will be for two to three years )

**Phase -2 : Centrally Initiated implementation**, which will cover all CFTI libraries

**Phase -3 : State Initiated Implementation**, which will cover all state funded university, college and school Libraries.

**Financial Targets:** Not available

## **Table Agenda No: 2**

- Proposal** : i) **Enhancement, Maintenance and Support of the HRD Ministry Website and**  
ii) **Design and Development of the Website of Minister of Human Resource Development;**
- Project Coordinator** : **Ms. V. Rajeswari, Sr. Technical Director, National Informatics Center (NIC).**
- Implementation Agency** : **National Informatics Centre Service Incorporated (NICSI)**

### **Background**

Ministry of Human Resource Development (MHRD) has been incorporated with an aim towards development of Human resource. The ministry is divided into two departments: Department of School Education and Literacy, which deals with the Elementary Education, Secondary & Higher Secondary Education and Adult Education, and the Department of Higher Education, which deals with University and Higher Education, Technical Education, Distance Learning, Language, Book Promotion. Present web site of the MHRD has been designed and developed by the NIC on CMS tool – Drupal. The website is bilingual. The URL of the Site (Rendering) is following:

<http://mhrd.gov.in> alias <http://education.nic.in>

The NIC has suggested that the present website of the MHRD needs enhancement and customization of 200 pages of the bilingual website along with fixing of issues if any.

Understanding the importance and significance of web presence in today's scenario, MHRD has also felt the need for redesigning its website as per the "Guidelines for Indian Government Websites". The following have been kept as the objectives for the re-designing and the development of the web-site:

- i) Provide a modern web presence to Ministry of Human Resource Development.
- ii) Provide ease of use and accessibility of information to various users, and
- iii) Ensure that the websites comply with the essential pre-requisites of UUU Trilogy i.e.; Usable, User-Centric and Universally Accessible.

Further the website of Hon'ble Minister of Human Resource Development needs to be designed with all dynamic features for updation and prescribed web accessibility features. The HRM website would also have administrative control for all the Modules and there would be one admin who will update /add /delete website content through Content Management System (CMS). It is proposed to include a Content Creator and Approver System wherein authorised content creator can upload data onto the website which after due approval by designated approver would be available to the Webmaster/Publisher for final hosting onto the website.

### **Proposal and Financial Implications:**

The issue was discussed with NIC. The NIC has submitted the two proposals to the Ministry to design and develop the website of Minister of Human Resource Development and further enhance, maintain and provide the support to the HRD Ministry website. The proposals received from the NIC are available at **Appendix-XIV and Appendix- XV.**

For enhancement, maintenance and to provide the support of the website for one year, NIC has submitted through NICS, the total estimate cost of Rs. 17, 37,095 /- The cost breakup is as follows:

<b>S. No.</b>	<b>Component</b>	<b>Total Cost (In Rs.)</b>
1.	Re-design, development, enhancement and support for one year (Annexure II (NICS PI )	
	Design Layout Changes Addition of New Functionality Custom Module Development Content Creation and uploading 200 Pages creation, etc	Rs12,23,196 /-
	Application Security Audit from CERT-In empanelled vendors and STQC Certification	
2.	Training, Audio, Video support (Annexure III (NICS –PI)	
	Conversion of all audio files into MP3 format and video files in flv format. Uploading the files on media/streaming server etc Training to all the users Monitor the HRM Website, etc	Rs. 5,13,899 /-
<b>Total Cost (Inclusive of all taxes)</b>		<b>Rs.17,37,095 /-</b>

For design and development of the Website of Minister of Human Resource Development, NIC has submitted through NICS, the total estimated cost of the project to be Rs. 3, 19,633.

The NIC has also requested that the funds may be transferred in favour of NICS, New Delhi as 100% in advance to ensure timely commencement & completion of the Project.

**The proposals of (i) Design and Development of the Website of Minister of Human Resource Development; and (ii) Further Enhancement, Maintenance and Support of the Website submitted by NIC through NICS at a cost Rs. 20, 56, 728/- (Rs. Twenty Lakhs Fifty Six Thousands Seven Hundred Twenty Eight ) is placed before the PAB of NMEICT for consideration and its approval.**

**Project Name:** Enhancement, Maintenance and Support for Ministry of Human Resource Development Website.

**Organization:** National Informatics Centre (NIC).

### **Project Implemented through National Informatics Centre Incorporated (NICSI)**

Ministry of Human Resource Development (MHRD) has been incorporated with an aim towards development of Human resource. The ministry is divided into two departments: Department of School Education and Literacy, which deals with the Elementary Education, Secondary and Higher Secondary Education and Adult Education, and the Department of Higher Education, which deals with University and Higher Education, Technical Education, Distance Learning, Language, Book Promotion. Understanding the importance and significance of web presence in today's scenario, MHRD has proactively identified the need for redesigning their website as per the "Guidelines for Indian Government Websites".

As per our understanding of the project, the following have been kept as the objectives:

- 1) Provide a modern web presence to Ministry of Human Resource Development
- 2) Provide ease of use and accessibility of information to various users
- 3) Ensure that the websites comply with the essential pre-requisites of UUU Trilogy i.e.; Usable, User-Centric and Universally Accessible

NIC has designed, developed and launched the Ministry of Human Resource and Development Website on CMS tool – Drupal. The website is bilingual.

The URL of the Site (Rendering):

<http://mhrd.gov.in> alias <http://education.nic.in>

The present website needs Enhancement and Customization of 200 pages of the bilingual website along with fixing of some issues. The present application architecture detail along with the Scope of work is given below:

#### **A. Application Overview and Architecture**

##### ***Distributed Web Application Development:***

MHRD existing web application has been developed using a distributed way in a clustering environment where rendering engine is in a separate cluster and the Management part is in another cluster and Database in a different cluster with fault tolerant mechanism in place.

The application has been developed in such a way to satisfy the above mechanism.

- i) Existing Application is developed in Drupal 7.0 (in LAMP environment) *with more than 100 custom modules which need to be studied and further customized to suit the current needs and optimization (response time should be < 1 S)*
- ii) Role based multiple administrators to manage various segments of the web application
- iii) Page wise theme and dynamic page specific menus and controls.
- iv) Bi-Lingual(English & Hindi)

## **B. Current issues in the existing site**

### **B.1 Design Level**

#### **i) Design Layout**

Theme based Design with customization is required in the

- Home Page
- Department of School Education and Literacy Page
- Department of Higher Education Page

And accordingly in all the inner pages

#### **ii) Browser Compatibility Issue**

- Compatibility with IE, Google Chrome and Mozilla Firefox

#### **iii) Fonts and CSS Level**

- Font Issue/CSS – Page, Table, Heading etc on creation of content
- Problem in creating table with CMS / Editor

### **B.2 Functionality Level**

- Breadcrumb level issues
- Who' Who (Multi level Access Control)
- MHRD Institution List (Multi level Access Control)
- Latest Updates
- Events (Multi level Access Control)
- Circulars(Multi level Access Control)
- Notification(Multi level Access Control)
- Tenders(Multi level Access Control)
- Photo Gallery(Multi level Access Control)

- Scholarship Updates
- Feedback
- Documents and Reports
- Search Criteria
- Student Corner
- Teacher Corner
- Success Story
- Social Media, etc

### **B.3 Access for uploading Updates (News/Events/etc):**

Provision is to be provided to all the Autonomous bodies of Ministry of Human Resource Development (MHRD) for uploading News/ Events/ Results/ Success Stories/ Achievements/ etc to MHRD website with approval mechanism. The uploading access is to be role based.

### **C. New Features**

- New themes
- Optimize response time <1s
- Custom Module Development (Hindi and English): Functionality wise approximately 100 module and sub-modules need to be designed and developed.
- Discussion Forum
- Hit Counter

### **D. Application Security Audit by CERT-in Empanelled vendor:**

The web application (with all distributed modules, rendering engine, admin ) is required to be audited by CERT-in Empanelled vendor only. Separate audit is to be carried out for the “Rendering” as well as for the “CMS” part of the site.

### **E. Support and Hand holding Mechanism:**

- i) Complete application along with security clearance would be completed within 2 Months (Content to be provided by Ministry)
- ii) Deployment of one experienced Drupal resource on-site for maintenance and development support for a period of twelve (12) months and to manage the existing application and coordinate with the development team (This would be a separate resource other than the resource engaged for the customization and enhancement of the existing application). The resource is to be deployed within one week of the issue of work order



- iii) Complete deployment, Installation and Configuration of the site on Staging, Rendering and CMS server including Database. Also creation and setup of local environment

## **F. Training and documents**

### **i) F.1 Documents**

- SRS
- DFD (data Flow Diagram)
- ERD (Entity Relationship Diagram)
- PP (Project Plan)
- Internal architecture of whole application
- Developers manual for every module, class, association
- Test Plan
- Test Cases and Test Result
- User's manual
- Super administrator manual
- Individual administrator manual

### **ii) F.2 Source Code:**

- Complete Source Code

### **iii) F.3 Training:**

- Two-Three days Onsite training for administrator and users Level
- 2 week developers training onsite for developers Level

## **Commercial Proposal**

**The total Cost of the Project is estimated to be Rs. 17,37,095 /-**

**NICSI PI is at next page.**

**Cost Breakup:**

<b>S. No.</b>	<b>Component</b>	<b>Total Cost (In Rs.)</b>
1.	Re-design, development, enhancement and support for one year (Annexure II (NICSI PI )	
	Design Layout Changes Addition of New Functionality Custom Module Development Content Creation and uploading 200 Pages creation etc	Rs.12,23,196 /-
	Application Security Audit from CERT-In empanelled vendors and STQC Certification	
2.	Training, Audio, Video support (Annexure III (NICSI –PI)	
	Conversion of all audio files into MP3 format and video files in flv format. Uploading the files on media/streaming server etc Training to all the users Monitor the HRM Website etc	Rs.5,13,899 /-
Total Cost (Inclusive of all taxes)		Rs.17,37,095 /-

The above Cost of Rs. 17,37,095/- includes NICSI Operating Margin and Service Tax @ 12.36 % as applicable.

The funds may be transferred in favour of NICSI, New Delhi as 100% in advance to ensure timely commencement & completion of the Project.

In case of any major requirement, a separate proposal will be submitted after the assessment of the work.

**Note : NIC Project Incharge would have the flexibility to re-appropriate the budget across heads as per the project requirement.**

Complete support to be provided for a period of one year (12 Months).

**Proposal** : **Design and Development of Website for Human Resource Minister, Ministry of Human Resource Development**

**Project Coordinator** : **Ms. V. Rajeswari, Sr. Technical Director, NIC**

**Organization** : **National Informatics Centre**

**Implementation Agency** : **National Informatics Centre Service Incorporated (NICSI)**

## **1. Introduction**

The website of Hon'ble Minister of Human Resource Development needs to be designed with all dynamic features for updation and prescribed web accessibility features. The HRM website would also have administrative control for all the Modules and there would be one admin who will update /add /delete website content through Content Management System (CMS).

It is also proposed to include a Content Creator and Approver System wherein authorised content creator can upload data onto the website which after due approval by designated approver would be available to the Webmaster/Publisher for final hosting onto the website.

## **2. Scope of Work – Functionality Covered**

The following broad features are to be developed in Hon'ble Minister of Human Resource Development website. The site map would include

- Know Your Minister
- HRM Office
- Our Ministry
- HRM & Press
- Media Gallery
- News & Updates
- Official Statements
- Social Media Updates
- Interact with Minister
- Ministers Message
- Auto Archival Policy

The proposed project would have following Board Components:

**Home Page:** This section is for all the users visiting the website. This will be the main page of the website which will contain links to all other sections. The Homepage will also have the News Updates pertaining to Hon'ble Minister. The Webmaster would be able to alter the contents of the links in various sections and their placement within the homepage as per requirement

**Hon'ble Minister Message:** This page would contain the message from the Hon'ble Minister to the general Public.

**Know your Minister:** Herein under this section the visitor to the site would be able to view the Hon'ble Ministers Profile etc

**HRM Office:** Herein under this section the visitor to the site would be able to view all the messages from Minister and HRM Officials contact details along with their work allocation.

**HRM & Press (Press Clippings / Statements):** Through this section the visitors to the site would be able to view all the Newspaper / Magazine clippings and speeches pertaining to Hon'ble Minister.

**Tour Programmes:** This page would have the date-wise list of all the current and previous Tour programmes of Hon'ble Minister. While visiting this page the visitor would be able to view the date-wise list of all the Tour programmes pertaining to the current Month and to view the Tour programmes of previous months the visitor has to click on Previous Tour programmes Link.

**Media Gallery:** All the Photographs pertaining to Hon'ble Minister would be listed under this section. Each photograph would have a brief description. All photographs would be listed in thumbnail (small) size with facility to download by the visitor. This section would also include the Video Gallery, Social Media Updates and Live Events.

**News Updates:** All the news updates pertaining to Hon'ble Minister can be accessed through this section.

**Official Statement:** All the Official Statements pertaining to Hon'ble Minister can be accessed through this section.

**Social Media updates:** Through this section the visitors to the site would be able to connect to Hon'ble Minister Pages on Facebook, Twitter like social media sites.

**Interact with Minister:** Through this section the visitors to the site would be able to directly interact with the Hon'ble Minister. While accessing this link the visitor would be able to view the Form wherein they would be able to fill-in their queries/issues/suggestions and send it to the Hon'ble Minister.

**Content Printing:** For each link there would be a print button and on clicking the system would open the page in a new window without Navigation and only the content and page header.

**Content Structure:** The website would have a level content structure i.e. there would be main links in the website. Under each main link, there would be sub-links. Under each sub-link there would be sub-links level 2 and so on.

**Page Title:** For each link created the admin would specify the title of page.

**Admin Panel:** For each link created the admin would specify the title of page.

## **Project Duration**

### **Software Development, Deployment & Training**

**The duration of the Software development, deployment & training would be 3 months.**

**Project Start Date** would be from the date on which the ministry officially approves the project or from the date of release of payment by the ministry.

### **Maintenance**

The maintenance phase of the project would begin after the completion of Software deployment.

### **Project Cost**

**The total Cost of the Project estimated to be Rs. 3, 19,633.**  
**NICSI PI is attached herewith as annexure - II**

**The funds may be transferred in favour of NICSI, New Delhi as 100% advance to ensure timely commencement & completion of the Project.**

**Proposal** : **Design and Development of Web based portal for Central University**

**Project In charge** : **Mr. P.K. Saha, Deputy Secretary, [pk\\_saha2008@yahoo.com](mailto:pk_saha2008@yahoo.com), 011-23073629, 09968428844**

**(Ministry):**

**Implementing Agency:** : **National Informatics Centre Service Incorporated (NICSI)**

### **Background:**

Information/data regarding various key parameters is essential to monitor and evaluate various policy and administrative decisions of Government of India. In absence of reliable data reporting system in place, the monitoring, analysis and evaluation/effectiveness of policy prescription of the Government becomes a meaningless exercise. Moreover, a lot of information is required not only for RTI but also for reporting it to various constitutional bodies including Parliament. The information is thus essential for effective decision-making.

It is thus proposed to create a web-enabled information system for monitoring of significant aggregate parameters, which shall be available for monitoring and reporting as per required formats. The information would be available to all concerned including Minister's office, Secretary, Additional Secretary (TE), Directors, Section as well as to the concerned institutions. The information would be required from all the Centrally Funded Technical Institutes.

Higher Education sector has witnessed a tremendous increase in its institutional capacity in the years since Independence. The number of Universities/University-level institutions has increased 18 times from 27 in 1950 to 504 in 2009. The sector boasts of 40 Central universities, 243 State universities, 53 State Private universities, 130 Deemed universities, 33 Institutions of National Importance (established under Acts of Parliament) and five Institutions (established under various State legislations). The number of colleges has also registered manifold increase with just 578 in 1950 growing to be more than 30,000 in 2011.

The Central Universities & Language Bureau of Department of Higher Education, Ministry of Human Resource Development deals with the Central Universities, which are 40 in number at present. These Universities are established by/under Acts of Parliament which have provisions for their academic and administrative functioning. His Excellency the President of India is the Visitor of the Central University and his role in the Central University, among others, include appointment of Vice Chancellor, nominating persons as his nominee on various authorities and committees of the Universities.

It is proposed to develop a Web Based system to deal with issues pertaining to the Central Universities to facilitate processing of the various requests from the universities and requisite functioning under the Act.

### **Scope of Work :**

During the Phase - I of the development the following modules as discussed are proposed to be taken up:

- i) **Committees and Reports:** Provision to upload Committees and Reports
- ii) **Central Acts and Ordinance:** Provision to upload all Acts and Ordinance and make them available to Ministry/Citizens/Institutions/
- iii) **Circulars/Orders/Notifications:** Provision to upload Circulars/Orders/Notifications for viewing single/all/multiple by Universities or by public.
- iv) **University Details :** Provision to capture basic details of the University like :
  - o Address
  - o Website URL
  - o Contact Details including Phone/Fax/email address
  - o Year of Establishment
  - o Logo
- v) **Profile of Vice Chancellor / Pro-Vice Chancellor/Registrar/Finance Officer/Controller of Examination:** Provision to capture VC, Pro-VC, Registrar and Finance Officer basic details including their tenure and contact details.
- vi) **Statutory Bodies:** Capture details of all the **statutory bodies'** i.e. **Academic Council, Executive Council, Court and Finance Committee.** Members details of each statutory body would be captured slot wise, with tenure, Social Category etc. Accordingly monitoring reports on tenure expiry, slot wise vacancy position, Visitor Nominees, Members holding multiple positions within university or across the universities etc
- vii) **Selection Committee:** Capture details of the selection committee of all teaching staff. It would be captured according to Faculty/Department wise. It would also capture the subject of specialization of the member. For Non teaching staff the committee details only for Registrar, Finance Officer and Controller of Examination are required to be captured.

- viii) **Expert Database Creation:** Creation of database (meta data information) of subject expert received or forwarded to the Ministry by Minister Office/Secretary/Joint Secretary/VIP reference/ Universities with facility for searching the database on parameters/criteria.
- ix) **Budget:** Provision to enter the financial year wise budget sanction under various components and utilization details.
- x) **Monitoring and Analytical Reports :**
- VC , Finance Officer, Registrar tenure expiry
  - Tenure expiry of various members of statutory bodies
  - Monitoring reports on holding multiple positions within the Universities or across the Universities in the various statutory bodies.
  - Monitoring reports of vacancies in statutory bodies.
  - Provision to search the biodata of subject expert from Expert database as well as from the teaching selection committees etc.

#### **PROJECT DURATION:**

##### **Software Development, Deployment & Training**

**The duration of the Software development, deployment & training would be 4 months.**

*Project Start Date* would be from the date on which the ministry officially approves the project or from the date of release of payment by the ministry. **The maintenance** phase of the project would begin after the completion of Software deployment for a period of 8 Months.

#### **PROJECT COST:**

##### **Estimated Project Cost**

**The total Cost of the Project Phase – I** estimated to be **Rs. 15, 33,822 /-**  
(The above cost includes NICSI operating margin and Service Tax @12.36 % as applicable)



## Cost Breakup

Estimated Cost of Software Development, Deployment & Training (Phase – I)

S. No.	Component	Activity to be Undertaken	Estimated Project Cost (In Rs)
1.	Software Design, Development, Implementation and Maintenance	Central University Portal :- <a href="http://cup.nic.in">http://cup.nic.in</a> Design and Development (4 Months) Preparation and Approval of Software Requirement Specifications (SRS) Application Design, Development and Implementation	Rs.14,68,294/-
2.	Training and Workshop	Training and Workshop Preparation of User Manual Conduct of workshop for training and hands-on session	
3.	Maintenance and Support	Maintenance and Support After implementation mail/telephonic support will be provided Additional Reports/Modifications level support will be given (*In case of major changes/requirements beyond the scope of assessment, a separate proposal after the assessment of the new work will be submitted)	
4.	Security Audit	Third party Application Security Audit clearance from CERT-In empanelled vendor	Rs.65,528/-
Total (The above cost includes NICS I operating margin and Service Tax @12.36 % as applicable)			Rs.15,33,822 /-

Estimated cost for **Software Maintenance for a period of 8 months is included in cost given.**

The cost quoted above relates only to the cost to be paid by the Ministry to NICS I. In addition, the cost associated with the TA/DA of officials from NIC will also have to be borne by Ministry. The NIC has requested that the funds may be transferred in favour of NICS I, New Delhi as 100% in advance to ensure timely commencement & completion of the Project.

**The proposals of “Design and Development of Web based portal for Central University” submitted by NIC at a cost Rs. 15,33,822/- (Rs. Fifteen Lakhs Thirty Three Thousands Eight Hundred Twenty Two ) is placed before the PAB of NMEICT for consideration and its approval.**

### **Table Agenda No. 3**

#### **Providing Wi-Fi at the Department of Higher Education, Ministry of HRD.**

##### **1.0 Background**

The wired connectivity at the Department of Higher Education, Ministry of HRD Shastri Bhawan has been provided by NIC. For enabling all Wi-Fi enabled devices to access this connectivity, a network is also required to be in place covering all offices of the Higher Education department at Shastri Bhawan. Towards this, BSNL was requested to get a technical feasibility study done and submit a report.

##### **2.0 Proposal**

In response, BSNL carried out a site survey at Shastri Bhawan. BSNL have shown their willingness to provide Wi-Fi connectivity at Shastri Bhawan and intimated that the total expenditure with 5 years AMC and FMS will be approximately Rs. 69,33,060 (Rs. Sixty Nine Lakhs Thirty Three Thousand and Sixty rupees only).

The proposal was discussed in detail in the meeting of the Implementation-cum-Monitoring Committee of NMEICT held on 16.06.2014; the committee was of the view that as connectivity at Shastri Bhawan has been provided by NIC, it would be better if NIC takes up the responsibility of providing Wi-Fi at the Department of Higher Education, Ministry of HRD. It was also brought out that the NICNET Network running at Shastri Bhawan already has a secured centralized Wi-Fi system. To extend to Dept. of Higher Education, some equipment will need to be added. An advantage would be that since in the proposed Wi-Fi setup, the Access Points would report to the centralized controller equipment managed by NIC, issues like Security would be taken care of with the NIC Policy already in place. The NIC has agreed for the same.

### 3.0 Financial Implication

The approximate cost for the equipment, LAN cabling etc, with 5 years AMC and FMS as given by NIC is given below.

Part	Unit Cost (approx.)	Qty	Total (inRs.)
Cisco Wireless Access Points (AIR CAP 2700) w/Clean Air; 3x4:3SS; Mod; Int Ant; A Reg Domain 802.11a/g/n/ac with 5 years off site Warranty support	<b>Rs. 39,231</b>	30	Rs. 11,76,930
Access Switch-POE for APs , Catalyst 3560C Switch 8 GE PoE (+) 2 x Dual Uplink IP Base with 5 years off site Warranty support	<b>Rs. 63,052</b>	04	Rs. 2,52,208
Wireless Controller license for management and control, security , WIPS etc.	<b>Rs. 18,707</b>	30	Rs. 5,61,216
LAN cabling cost			Rs. 1,75,000
One Manpower for 5 years dedicated to managing and supporting the HE Wi-Fi network	<b>Rs. 30,000</b>	60 months	Rs. 18,00,000
<b>Total Cost</b>			<b>Rs. 39,65,354</b>

The above proposal of providing Wi-Fi at the Department of Higher Education, Ministry of HRD at a cost of Rs. 39,65,354 with NIC as Implementing Agency is placed before the PAB of NMEICT for consideration and its approval.

#### **Agenda Item No: 4**

**Proposal** : **An Open Source Indian MOOCs Platform**  
**PI** : **Prof. Deepak B Phatak**  
**Co-PIs** : 1. **Prof.KannanMoudgalya, Chemical Engineering Department – IIT Bombay**  
2. **Prof.VikramGadre, Head CDEEP, Convenor IDP Educational Technology – IIT Bombay**  
3. **Prof. Sridhar Iyer, CSE Department, and Associate faculty of IDP on ET – IIT Bombay**  
4. **Prof.KameswariChebrolu, CSE Department – IIT Bombay**  
**Institute** : **IIT Bombay**  
**Control No.** : **DMA1606201413199**

#### **Background**

- 1) **MOOCs** (Massive Open Online Courses) have emerged as a very potent mechanism to extend the reach of quality education, on a scale hitherto considered impossible. In less than 3 years, a number of organizations have started offering such online courses to millions of learners across the world.
- 2) These courses are offered by well-known professors of top global universities. Many courses have seen enrollment ranging from 50,000 to 2,00,000 students.
- 3) MHRD had taken an initiative as a part of Indo–US dialogue on higher education, to explore the possibility of collaboration with organizations offering MOOCs.
- 4) IIT Bombay started looking at MOOCs seriously about 2 years ago. One objective was to make some of their courses available to global learners. The other and equally important objective was to develop a MOOCs platform tailored to Indian educational needs for all levels of education.
- 5) More specifically, while executing the T10KT project for training 10,000 teachers at a time, it was found that the open source Moodle platform which is used currently, does not scale beyond 2,000 to 2,500 concurrent users
- 6) After a detailed study, IIT Bombay decided to collaborate with edX, which was one of the organizations identified through MHRD initiative. AnMoU was signed in New Delhi in early 2013.

- 7) Some deficiencies have been discovered in the MOOCs model, if it is to be used for students enrolled for regular degrees of a university.
- 8) A 'Blended' model has been developed by IIT Bombay, which will be tried this year for students of IIT Bombay, along with students of a few selected autonomous institutes.
- 9) One of the professors at IIT Bombay has developed an experimental platform called Bodhitree, catering to the flipped classroom approach, which is a component of our blended model.
- 10) It is proposed to build and operationalize an Open Source Indian MOOCs platform, to cater to various needs of Indian educational system, such that MOOCs can be offered easily in different domains.
- 11) The proposal is to suitably modify and enhance the Open Source edX platform, incorporate components of Bodhitree where relevant, and install it on a cloud.
- 12) This will enable various courses in different domains to be offered from within India, directly to all Indian students.
- 13) It is proposed to establish one or more consortia of Indian educational Institutes, e.g. a consortium of centrally funded Institutions.

### **Sustainability of the project**

- 1) It is proposed that a special purpose vehicle (SPV) be set up to handle all operations of such offerings.
- 2) IIT Bombay has already resolved to setup a section 25 company for this purpose. Currently, the detailed structure for such a company is being worked out.
- 3) Initial financial support is essential to kick-start such a venture (EDX, for example, is a similar not-for-profit company set up by MIT and Harvard, with an initial contribution of US\$ 60 million).
- 4) It is proposed to set up such a company as a part of this project

## **Methodology**

- 1) For the development of the main MOOCs platform, the methodology proposed is to build on two existing systems. One is the open edX platform, and the other is the Bodhitree that has been developed at IIT Bombay and has been used in the flipped classroom model.
- 2) The design and offering of MOOCs will be done using the edX method which IIT is already using to offer global MOOCs, along with a blended MOOC methodology developed at IIT Bombay.
- 3) IIT Bombay proposes to use their considerable experience in running large scale activities under T10KT project, where MOOC-like offerings using Moodle, Clickers, and internet are being used to reach out to 10,000 teachers at a time.

## **Deliverables**

### **2014-15 (Year I - Rs 1565 Lakhs)**

- a) Procurement and installation of the Development/Test system, Mini cloud, Hadoop, and other ancillary equipment.
- b) Delivery of early version the platform to be deployed on T10KT servers, and will be made available to a limited number of Institutions to run their courses. In case the NMEICT server cloud is operational by then, the platform will also be deployed on that cloud.
- c) Delivery of version 1 of the platform to be deployed on the mini-cloud system in IIT Bombay, and also on the NMEICT cloud in Delhi.
- d) Two basic courses in engineering will be designed and developed at IIT Bombay to run on this platform. It will be attempted to offer these in blended MOOCs as pilots with limited enrollment of 10,000 to 30,000 students per course, subject to acceptance by other universities.
- e) Formation of section 25 Company.

### **2015-16 (Year II - Rs 1008 Lakhs)**

- a) Delivery of a tailored version that can be used on smaller servers within individual Institutions/Colleges.
- b) Establishment of one or more Consortia (e.g., Centrally Funded Institutes). Guidelines for Consortia and section 25 company, to provide services for running MOOCs
- c) Training of teachers on design of MOOCs on the platform.
  - Six short online familiarization workshops on use of the platform.
  - Two of these will be conducted by IIT Bombay for Teachers/staff of various Engineering and Science colleges.
  - Four or more will be conducted by experts from other domains using the platform, with support from the project.

d) Courses for students

- Two more basic courses in engineering will be designed and developed at IIT Bombay to run on this platform. These will be offered in blended MOOCs as pilot.

**2016-17 (Year III -Rs 391 Lakhs)**

- a) Version 2 of the platform with enhanced state-of-art features.
- b) Section 25 Company to start working independent of the Mission Support.
- c) It is expected that a number of other Institutions and universities/Indian consortiums will offer MOOCs on this platform.

**Project Duration**

The duration of the pilot phase of the project is 3 years from award of funds

**Proposed Budget**

**Total Recurring and Non-Recurring Budget**

Rs. Lacs	Year - I	Year – II	Year – III	Total
Non-recurring	1050	325	0	1375
Recurring	515	683	391	1589
<b>Total</b>	<b>1565</b>	<b>1008</b>	<b>391</b>	<b>2964</b>

**Total amount required: (Rs. Lacs)**

	Year I	Year II	Year III	Total
Equipment and Infrastructure	1050	325	Nil	1375
Salary	225	274	150	649
Course Design	40	40	40	120
Training Workshops	100	200	100	400
Consumables	30	50	30	110
Travel	50	60	40	150
Contingency	20	30	20	70
PI Honorarium (budgeted at 3%)	50	29	11	90
<b>Total</b>	<b>1565</b>	<b>1008</b>	<b>391</b>	<b>2964</b>

## Details of Budget Requirements

The main funding requirements will be for the software development, and the minimal hardware essential for development and for pilot delivery.

Major items of the equipment are listed below with estimated costs:

	Item	Estimated cost (in Rs Lakhs)
1)	Mini-cloud system for pilot operations. (with a large number of virtualized servers, storage, and open source software support)	Rs. 525
2)	Hadoop system for MOOCs analytics	Rs. 375
3)	Development and test environment	Rs. 75
4)	Networking Equipment	Rs. 25
5)	Miscellaneous (PCs, Printers, etc)	Rs. 30
6)	Associated power and environmental infrastructure	Rs. 20
7)	Augmentation of processing power and storage (Year II)	Rs. 325
	Total	Rs. 1375

## Details of Salary Calculations

Some details are given below, reflecting the salary calculations

Position	Range (Rs '000).	Average (Rs. '000)	Numbers	Total Per Mth (Rs. Lac)	Total Months	Total Amount (Rs. Lac)
Senior Staff/Advisors	60-90	75	10	7.5	12	90.0
Senior Software Engineers	40-60	50	6	3.0	12	36.0
Programmers	25-40	30	15	4.5	12	52.0
Admin staff	15-40	25	10	2.5	12	30.0
Documentation and Dissemination staff	25-40	30	5	1.5	12	18.0
Workshop staff	30-50	40	10	4.0	12	48.0
Total						274.0

These are for the team which will be working in year 2 of the project. In the first year, the salary budget required will be a bit less (for about 9 to 11 months for different staff). In the third year, when most of the operations are expected to be run by the SPV, the budget requirement is substantially less.

**The above proposal by IIT Bombay for setting up an Open Source Indian MOOCs Platform at a cost of Rs. 2964 Lacs is placed before the PAB of NMEICT for consideration and in principle approval.**



# Development of National Digital Library of India

## *Towards Building a National Asset*

Initial Concept Developed by Indian Institute of Technology Kharagpur. Pilot Phase proposed to be carried out by a Consortium of CFTIs, Colleges and Schools

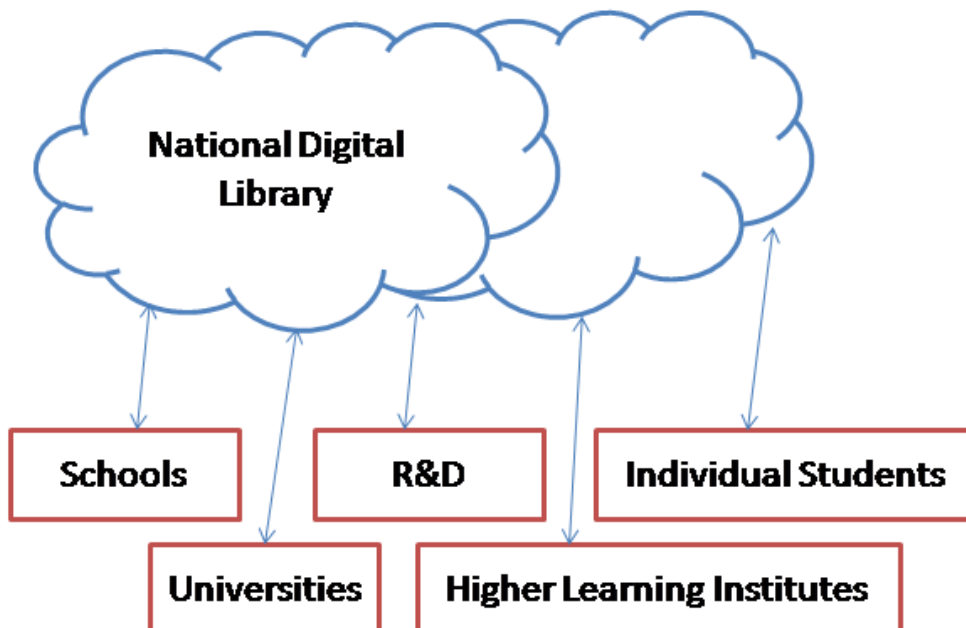

# Development of National Digital Library of India

## *Towards Building a National Asset*

**Initial Concept Developed by Indian Institute of Technology (IIT) Kharagpur**

**Pilot Phase proposed to be carried out by a Consortium of CFTIs, Colleges and Schools**

July 7, 2014

### **A. Introduction:**

A National Digital Library is a national asset that is a key driving force for its education, research, innovation and knowledge economy. It is essential for a country like India to have a vibrant National Digital Library to rapidly develop its knowledge power enabling it to cover gaps that exist in the wide range from literacy to advanced knowledge discovery and development of scientific knowledge. It will also enable integrated knowledge gathering on diverse topics on core issues from economic, strategic and social sectors. Recently there have been significant developments in National Digital Library development in USA, Europe and some other developed nations. In the past there have been several efforts in India at developing and disseminating digital content for educational purposes. These all need to be harnessed into to combination of integrated and federated entity that is a living repository of knowledge, tools and enablers that can not only educate but also enable a billion minds to their true potential. This document presents a brief outline on the background, objectives, structure and methodology for the National Digital Library and proposes a Pilot project under the NMEICT programme of MHRD to initiate this activity through a consortium of CFTIs, colleges and schools. The Pilot Phase of the project is expected to develop the overall framework that can subsequently be refined and extended in two subsequent phases all over the country. In addition the Pilot Phase will help collate (and if needed generate) large number of e-contents for school, college and higher category students with special emphasis on the e-learning, virtual library and technology enhanced learning design covering the needs of learners with differing abilities, expectations and socio cultural background. This project will also enable some key national knowledge discovery and immersive learning platforms built around this Digital Library. It will also encourage entrepreneurial development of tools around this platform. In its final contour the system may serve as a pan-India virtual teaching-learning-evaluation-knowledge discovery and innovation platform, a key national asset.

Some of the basic statistics are as follows:

- **Schools & Higher Learning Institutions**

- There are 1,24,500 secondary schools and over 11 Lakh elementary schools spread across the country and employing more than 71 Lakh teachers. [Source: MHRD – NISG Report]
- There are 642 Universities, 34908 colleges and 11356 Stand Alone Institutions in India [Source: AISHE 2011-12]

- **Education market growth**

- In India education market growth is estimated to be US\$ 135 billion by 2020, of which the e-learning market alone will constitute US\$ 7 billion. [Source: Ernst & Young]

- **Drivers of the Growth**

- Huge growing student base
- Lack of quality e-content in various digital forms and formats
- Poor quality of connectivity due to lack of infrastructure

The above statistics shows that there is an immediate need to create and disseminate learning objects in different forms and formats for school to higher education students and teachers. The National Knowledge Network (NKN) and the National Mission on Education through Information and Communication Technology (NME-ICT) have been engaged in providing content and tools to colleges, institutes and universities using ICT facilities through high speed data connectivity. Again we have several Libraries and Knowledge Repositories which are the knowledge houses which maintain resources both in print and electronic forms. However, with the advent of digital technology and Internet connectivity, the library scenario in all types (school libraries, academic libraries, public libraries and R&D libraries) is changing rapidly. Many Libraries have developed Institutional Digital Repository (IDR) to preserve abstracting and full-text data for digital preservation and online access. Also large numbers of open access e-resources are available to access from different portals. There are some digital library projects in India to digitize physical contents and preserve digitally in digital library. Yet not much effort has gone in to take connect and provide access and content to school library users. All these available electronic resources are not indexed centrally to provide single window search facility to the users. As a result the users are facing problem to access those e-resources due to several reasons including:

- Users have to visit individual web site to access e-resources
- Users need to learn retrieval techniques / search techniques separately as different Digital Library (DL) follows different DL software (and DL software employs different text retrieval engines (like Solr, MGPP, Lucene, Zebra etc)

- Few e-Learning environments are available for the students and teachers that access information from all available sources
- Non integration of learner-learner, teacher-teacher and teacher-learner communication tools within learning environment
- Learning resources are generally outside the integrated learning environment
- Distance mode of learning in India is helping only to increase learner-base not the knowledge base
- In most of the cases user interfaces are not interactive, collaborative and participative
- No Single window search facility is not available of all resources
- Few mechanisms are available for differently abled learners
- Tools for knowledge discovery that enable integration and collation of available knowledge from various repositories to create a knowledge archive on various subjects is not yet available for scholars

In view of these, there is a need to develop a National Digital Library in India to collect, preserve and disseminate all the intellectual output of our country to provide online access to school level to post graduate level including technical education. Central Library of IIT Kharagpur has already developed an interoperable Institutional Digital Repository to preserve the intellectual output produced by the faculty members, students and staff. This expertise can be utilized to design and development of National Digital Library in India.

## **B. Digital Library Initiatives in India and Abroad:**

### **B1. Digital Library initiatives in India:**

- 1. National Mission on Education through Information and Communication Technology (NME-ICT):** Under this project all the colleges, institutes and universities are being provided with content, tools and technologies so that high quality e-content could be reached to the teachers and students of educational organizations using ICT. A bouquet of such tools have been developed initially through pilot phases and then through the main phase. Other than the NPTEL project mentioned earlier, this programme has several flagship projects including but not limited to Virtual Laboratories, Pedagogy, Talk210K Teachers, Direct Teaching 100s of college students, etc.
- 2. National Programme on Technology Enhanced Learning (NPTEL), Web Site:** <http://www.nptel.iitm.ac.in/> - A project funded by the Ministry of Human Resource

Development India (MHRD), provides e-learning through online Web and Video courses in Engineering, Sciences, Technology, Management and Humanities. This is a joint initiative by seven IITs and IISc Bangalore and has become one of the most popular educational video materials in the world.

**3. NISCAIR - National Institute of Science Communication and Information Resources (NISCAIR) ,** It works to collect / store, publish and disseminate S&T information through a mix of traditional and modern means, which will benefit different segments of society. The following are the major initiatives taken by the NISCAIR.

- **National Science Digital Library at NISCAIR**  
<http://www.nsdli.niscair.res.in/>
- **NISCAIR Online Periodicals Repository**  
<http://nopr.niscair.res.in/>
- **NISCAIR Knowledge Resource Consortium**  
[http://124.124.221.7/indexpage.php\](http://124.124.221.7/indexpage.php)
- **National Union Catalogue of Scientific Serials in India (NUCSSI)**  
<http://nucssi.niscair.res.in/>

**4. Digital Library of India (Million Book Project) -** Setting up of Mega Centres and Scanning Centres in collaboration with Indian Institute of Science, Bangalore and Carnegie Mellon University, USA : Under the collaborative Programme, scanners for these centres were provided by Carnegie Mellon University, USA, under Million Book Universal Digital Library Programme. **Hosted by:** Indian Institute of Science, Bangalore in co-operation with CMU, IIT-H, NSF, ERNET and MCIT for the **Govt. of India** and 21 major participating centres. Website: <http://www.dli.ernet.in/>

- **Sanskrit Books: Website** <http://sanskritdocuments.org/>

**5. Indira Gandhi National Centre for the Arts (IGNCA) -** Development of National Databank on Indian Art and Culture

- **Kala Sampada**  
<http://www.ignca.nic.in/dlrich.html>
- **Kala Nidhi**  
[http://ignca.nic.in/kn\\_body.htm](http://ignca.nic.in/kn_body.htm)

6. **NATIONAL MISSION ON LIBRARIES (Project National Virtual Library of India)**  
<http://www.nmlindia.nic.in/>
  
7. **INDEST-AICTE Consortium, Web Site:** <http://paniit.iitd.ac.in/indest/>. The Consortium is engaged to subscribe e-resource for all IITs, NITs, IISc, and IISERs etc., funded by MHRD
  
8. **UGC-INFONET Digital Library Consortium (INFLIBNET), Web site:** <http://www.inflibnet.ac.in/> , Information and Library Network (INFLIBNET) Centre is an autonomous Inter-University Centre of the University Grants Commission (UGC) of India. The consortium is also engaged to subscribe e-resources for University Libraries and colleges.
  - **Shodhganga - A Reservoir of Indian Theses**
  
- 8) **Muktabodha – DL on cultural heritage @** <http://www.muktabodha.org/>
  
- 9) **Traditional Knowledge Digital Library - 1200 Ayurvedic, Unani and Siddha Formulations @** <http://www.tkdil.res.in/tkdil/langdefault/common/Home.asp?GL=Eng>
  
- 10) **Rare Bengali books - State Central Library, Kolkata @** [http://www.wbpublibnet.gov.in:8080/openenrichv41/LIBRARY\\_new/html/health\\_department.jsp?page=http://dspace.wbpublibnet.gov.in:8080/jspui](http://www.wbpublibnet.gov.in:8080/openenrichv41/LIBRARY_new/html/health_department.jsp?page=http://dspace.wbpublibnet.gov.in:8080/jspui)
  
- 11) **Central level agencies such as NCERT, NUEPA, NIOS, and RIE** conducted various workshops & launched various ICT based programs
  
- 12) **NCERT** had put all its course contents online form class 1-12
  
- 13) There are domain related information like Legal databases and Legal e-Libraries, Medical e-Libraries, and other similar sources.

## B2. Digital Library initiatives in Abroad

- 1. MIT Open Course Ware | Free Online Course Materials** – MIT OpenCourseWare is a web-based publication of virtually all MIT course content. OCW is open and available to the world and is a permanent MIT activity. Web Site : <http://ocw.mit.edu/index.htm>
- 2. Hathi Trust Digital Library | Millions of books online** – Hathi Trust is a partnership of academic & research institutions, offering a collection of millions of titles digitized from libraries around the world. Web Site : <http://www.hathitrust.org/>
- 3. Project Gutenberg** – Project Gutenberg offers over 45,000 free e-books.  
Web Site: <http://www.gutenberg.org/>
- 4. Alexandria Digital Library:** The Alexandria Digital Library (ADL) is a distributed digital library with collections of geo-referenced materials. ADL includes the operational library with various nodes and collections, and the research program through which digital library architectures, gazetteer applications, educational applications, and software components are modeled, prototyped, and evaluated. Website: <http://www.alexandria.ucsb.edu/>
- 5. California Digital Library:** The California Digital Library supports the assembly and creative use of the world's scholarship and knowledge for the University of California libraries and the communities they serve. The library provides its community with more digital material including more than 21,000 electronic journals, tens of thousands of electronic books. Website: <http://www.cdlib.org>
- 6. Networked Digital Library of Theses and Dissertations:** Dissertations (the "Corporation") is a non-stock corporation duly formed under the provisions of the Virginia Non-stock Corporation Act. The Library is an international organisation dedicated to promoting the adoption, creation, use, dissemination, and preservation of electronic analogues to the traditional paper-based theses and dissertations. Website: <http://www.ndltd.org>
- 7. Library of Congress:** The National Digital Library programme of Library of Congress (LoC), USA has created an American Memory Database (AMD). AMD, the flagship of the LoC's digital services, offers multimedia collections of digitised documents, photographs, recorded sound, motion pictures, and text from the American historical collections of the LoC and other institutions. It has now more than 7.5 million digital items from more than 100 historical collections: website: <http://www.loc.gov/library/libarch-digital.html>

8. **National Science Digital Library (NSDL)** – The National Science Digital Library provides high quality online educational resources for teaching and learning, with current emphasis on the sciences, technology, engineering, and mathematics (STEM) disciplines—both formal and informal, institutional and individual, in local, state, national, and international educational settings. Web Site : <https://nsdl.org/>
  
9. **Digital Public Library of America** – The Digital Public Library of America brings together the riches of America’s libraries, archives, and museums, and makes them freely available to the world. It strives to contain the full breadth of human expression, from the written word, to works of art and culture, to records of America’s heritage, to the efforts and data of science. DPLA aims to expand this crucial realm of openly available materials, and make those riches more easily discovered and more widely usable and used, through its three main elements:
  - a. A *portal* that delivers students, teachers, scholars, and the public to incredible resources, wherever they may be in America.
  - b. A *platform* that enables new and transformative uses of our digitized cultural heritage.
  - c. An advocate for a strong *public option* in the twenty-first century.
  
10. **Telematics for Libraries:** The Telemetric for Libraries program of the European Commission (EC) aims to facilitate access to knowledge held in libraries throughout the European Union while reducing disparities between national systems and practices. While it's not exclusively devoted to digital libraries—the program covers topics such as networking (OSI, Web), cataloging (OPACs), imaging, multimedia, and copy-right, among others—many of the 100 or more projects funded by the European Commission do cover issues and activities related to digital libraries. Web site: <http://cordis.europa.eu/libraries/en/libraries.html>
  
11. **National Digital Library Initiatives in Europe:** ( France-Gallica, Germany- Global Info, the German Digital Libraries Project, Finland-National Electronic Library, Sweden- Project Runeberg, Spain-Memoria Hispanica, etc)
  
12. **The British Library's Digital Library Programme, London:** (aims to establish digital information services based on the content of the British Library's varied collections, and then to develop the capabilities to work with these collections in new and different ways while improving access to them from all over the world)



**13. Electronic Libraries (eLib) Programme, UK:** (The Hybrid Libraries project aims to integrate electronic products and services with the traditional functions of a library. The goal is for a library user to be able to use a single interface to discover and retrieve all of a library's resources, both internal (physical materials) or external (Internet resources)

**14. Other Efforts** There are several other efforts in countries in Asia (Singapore), Australia, etc.

### **B3. Major Gaps**

- Total number of classrooms in India- 4Mn, out of which 0.15Mn is having some or little facility of ICT and e-contents.
- 95% of the colleges still do not have basic amenities [Source: Rothin Bhattacharya]
- Many remote colleges do not have e-Learning content or access nor infrastructure
- Lack of single point of reference for integrated digital content for variety of user groups
- No specific ICT tools and e-contents present for differently abled students in most of the schools, colleges and universities.
- As there is a technology shift i.e. from PC to Tables to Mobile devices, henceforth many contents needs to be converted to suitable format. Like EPUB data is more suitable for tablets to access rather than PDF data file.

### **B4. Possible ways to address the above Gap**

- ICT and e-contents @Schools, @Universities, @Colleges will help us to minimize this gap.
- Collaborative e-Learning Framework needs to be implemented where all the stakeholders' works together in the learning phase.
- Self Based Learning Framework (SBLF) will next most important learning phenomena therefore digital Library access is required for self based learning
- Tablet & mobile devices will also play a major role in SBLF.
- New apps will be designed and develop for accessing e-contents from proposed National Digital Library
- Many Entrepreneurs will participate in this project in future to design and develop application software for providing value added services.

## C. Objectives:

- To develop National Learning Object Repository spanning school level to PG level including technical education.
- To build a national learning object repository providing free access to quality e-contents and education to all students at primary, secondary and higher education level.
- Enable improvement in quality of learning by implementing various learning objects.
- Access to near real-time and better quality data for decision support.
- Design and development of OAI-PMH Server for metadata harvesting at National Level.
- Initiative to make each existing operational Digital Library OAI/PMH-compliant.
- Contents from each digital repository of India will be harvested with the help of OAI-PMH protocol. Harvested digital contents will be indexed in one Central server for online access
- Born digital in-house resources produced by the faculty members, staff, and students to be collected and uploaded into the National Digital Library Server
- To provide online document deliver services of licensed e-resources across the country
- To provide Cloud based solutions and support to university and college libraries for running their DL server in 24 X 7 mode
- Design and Development of a web-scale Discovery Server which will provide single window search facility of all e- resources collected from different Institutions, Universities and different Digital Library projects and all open access learning resources
- Unicode-compliant multilingual environment will be created for storing, processing and retrieving of indigenous digital contents with regional language based interfaces
- Collaborative Learning Management Tools and Technology will be implemented
- Virtual e-Learning will be implemented to help the remote access at National Level
- To provide infrastructural support to school and college libraries to access the learning materials from NDL
- To have special verticals for various levels including schools, sciences, arts, commerce, law, economics & social sciences. medicine
- To develop Immersive Learning Platforms to study subjects ranging from school geography, history and science to advanced technical topics in engineering, medicine, architecture and social sciences
- To enable and develop several Digital Knowledge Platforms for several key national research initiatives like Himalayas, Ganga, etc to integrate knowledge from various sources and connecting them to the National GIS programmes and their platforms.

## D. Coverage of Learning Objects:

- Contents of all existing Digital Library projects, individual Institutional Digital Repositories developed by different universities, institutions, colleges, etc.
- Contents of all open access resources (e-books, e-journals, e-database, etc.)
- Faculty publications (last ten years 6, 80,437 articles were published from India which are indexed in SCOPUS database) but most of these articles are not accessible. However, author can upload their post print/pre-print article into their institute's IDR ( see website: <http://www.sherpa.ac.uk/romeo/>)
- PhD and D.SC theses of all academic Institutions and universities.
- In-house resource of class lecture notes, PPTs, various reports, tutorials, Course materials, working papers, previous year question papers, Instructor materials, reference materials, events, etc.
- E-books, which are subscribed as ownership model can be downloaded and uploaded into the Institute's IDR ( IIT Kharagpur has more than 1 Lakh e-books as ownership model )
- NCERT school e-books
- Integration of OPAC data of all academic Libraries
- Subscribed journal's articles of academic libraries can be downloaded and uploaded into IDR
- Legal databases
- Union catalogue of journals print and electronic subscribed by all academic libraries for providing document delivery services
- Audio, video, learning materials

### The following users will be initially targeted

- **School Library users**
- **College Library Users**
- **University Library Users**
- **Higher technical education Library users**
- **Legal Community Users (initially academic, then Professional)**

## E. Methodology:

- Identification of learning objects on global scale;
- Design of selection parameters (initially emphasis would be given on open learning objects)
- Development of a composite software architecture (digital archive to store learning objects, Learning Content Management System (LCMS) to provide teaching-learning-evaluation functionalities, Search and retrieval layer with Indic-script-enabled user interface);
- Selection of learning objects and incorporation of metadata (SCORM-compliant domain-specific metadata schema will be used for the purpose);
- Testing and debugging of NDL.

## F. Project Completion Plan

The whole project will be divided into 3 phases. Initially a Pilot Project is proposed.

### **Phase -1: Pilot Project initiated by IIT Kharagpur in collaboration with some other selected CFTIs**

including IITs, NITs and Schools libraries, Legal Libraries and INFLIBNET (This Pilot project is estimated to cost Rs 40 crore to 100 crore depending on scope and span. The Pilot project will be for two to three years)

### **Phase -2: Centrally Initiated implementation**, which will cover all CFTI libraries

**Phase -3: State Initiated Implementation**, which will cover all state funded university, college and school Libraries.

**OVERVIEW OF STEPS FOR PILOT PHASE:** The following different steps will be involved to implement the project in its Pilot Phase

### **Steps 1: Metadata Harvesting from Existing Digital Repositories in India**

Metadata Harvester Server will harvest the metadata through OAI-PMH from existing IRD of IITs, NITs, Universities & Other higher learning R&D Institutions.

**Technology:** OAI-PMH - Open Archives Initiative Protocol for Metadata Harvesting is a protocol developed by the Open Archives Initiative. It is used to harvest (or collect) the

metadata descriptions of the records in an archive so that services can be built using metadata from many archives.

## **Step2: Development of New Digital Repository**

New Digital Repository will be designed and developed by IIT Kharagpur where all the learning objects will be uploaded like Faculty Lecture Notes, PPTs, Faculty Publication, Projects & Annual Reports, Thesis & Dissertations, e-books, e-journals, Open Learning Objects, CBSE Courseware, Content from other DL in India etc,. Metadata Harvester Server will also harvest metadata through OAI-PMH from the newly developed digital repositories.

**Technology:** Dspace, Java, Apache Tomcat, Maven & PostgreSQL as RDBMS. Dspace is an open source digital Library software package typically used for creating open access repositories for scholarly and/or published digital contents. It is a joint effort between developers from MIT and HP Labs. Cloud based services (PaaS, HaaS, and SaaS) will be provided to the participating institutions and universities to develop their own digital repository.

## **Step 3: Development of Central Indexing and Resource Discovery Server**

All the learning objects will be Indexed and Stored in Apache Solr, which works as resource discovery server. This server will provide a single window search facility of all resource to users. It will also provide an **easy resource retrieval interface for the school and differently abled students.**

**Technology:** Apache lucene Solr will be used for resource discovery. Solr is an open source enterprise search platform from the Apache Lucene project.

## **Step 4: Development of Access Mechanism:**

IEEE-LOM meta-data schema and SCORM standard model: The education model will be followed in this project by Open Educational Resources (OER) framework which is freely accessible, openly licensed documents (through Creative Commons) and media that are useful for teaching, learning, educational, assessment and research purposes. Therefore, Open Digital Rights Language (ODRL) Ver. 2 will be used for accessing the open e-contents. ODRL will be implemented in three serializations: XML, RDF (Resource Description Framework), and JSON. ODRL is also adopted by the Open Mobile Alliance (OMA) as their core standard for mobile media content protections and for managing digital objects. To date, ODRL is arguably the largest mobile implementation of a rights language, currently operating on over a billion compatible devices. [Source: Wiki]

Login-Password based Access Mechanism: This type of mechanism will be implemented for limited users like administrators, teachers, librarians etc.

### Step 5: Development of Collaborative E-Learning Framework

Moodle Server will be installed and configured at IIT Kharagpur and other participating Institutions. It will be a course management server to implement the collaborative learning framework. Students will be able to register for online course and teachers will be able to take their lectures, online test, assignment, chat and provide answer to the student's queries. The technology will also be implemented for all types of devices i.e. PC, Mobile phone, Tablets etc. Therefore, self based learning model becomes more important with the use of tablets and mobile apps.

**Technology:** Moodle, IT is a free software e-learning platform, also known as a Learning Management System, or Virtual Learning Environment (VLE).

Android Apps will be developed as per requirements for the Virtual Learning Environment. Android Apps for **Tablets** may be considered as reusable learning applications.

### Step 6: Knowledge Discovery Framework (KDF)

Knowledge Discovery Framework will be implemented with two key models 1) KDD – Knowledge Discovery in Database and 2) Knowledge Discovery in Database Process.

KDF assist students in extracting useful information (knowledge) from the rapidly growing volumes of data. At the core of KDD process is the application of data mining methods for pattern discovery.

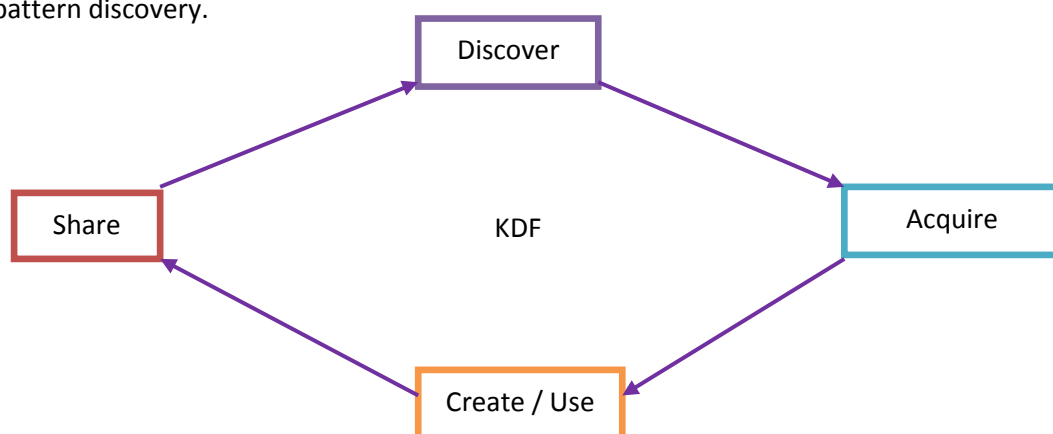

The above figure shows creation / use of the resource then created new resource is shared or publisher so that it may be further used. The newly shared resource is discovered which is finally acquired by the intelligent system in its knowledge repository.

**Technology:** Integration of new digital repository will always develop the knowledge base, and the various pattern searches, Boolean search; phrase search techniques will enable the users to locate the pinpointed e-resources.

### **Step 7: Differently-abled and Immersive Learning Projects**

Some platforms related to learning for differently abled people as well as new technologies for scalable immersive learning through visualization and interactive multi-media and gesture based communication will be explored and integrated.

### **Step 8: Specialized e-learning Verticals**

We may plan to pilot some special verticals for areas related to schools, science, arts, commerce, law, medicine, economics & social sciences

A diagram of the proposed Pilot Phase National Digital Library project and a snapshot of the Institutional Digital Repository developed by IIT Kharagpur are presented in the in the subsequent pages.

### **Contact Details:**

Prof Partha P Chakrabarti  
Director  
Indian Institute of Technology Kharagpur  
Kharagpur 721302 India  
Email: [director@iitkgp.ernet.in](mailto:director@iitkgp.ernet.in), ppchak@cse.iitkgp.ernet.in

Dr B Sutradhar  
Librarian  
Indian Institute of Technology Kharagpur  
Kharagpur 721302 India  
Email:bsutra@library..iitkgp.ernet.in

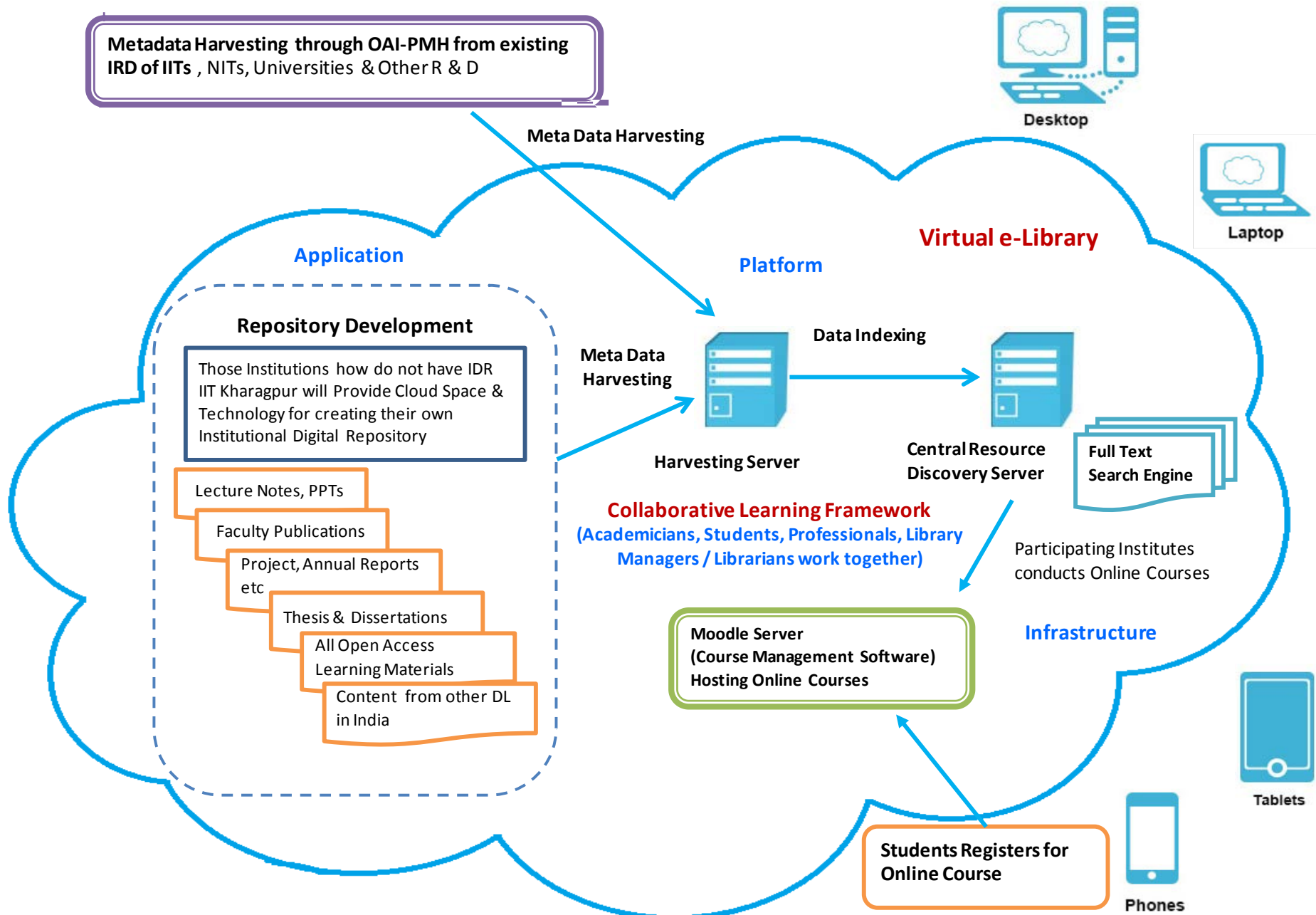

IIT Kharagpur may provide cloud based services (PaaS, HaaS, and SaaS) for participating institutes to develop their own digital repository, journal publication etc by using open source software and open standards.



Interoperable Institutional Digital Repository (IDR) developed by Central Library IIT Kharagpur: Web Site:  
<http://10.17.250.203:8080/xmlui/>

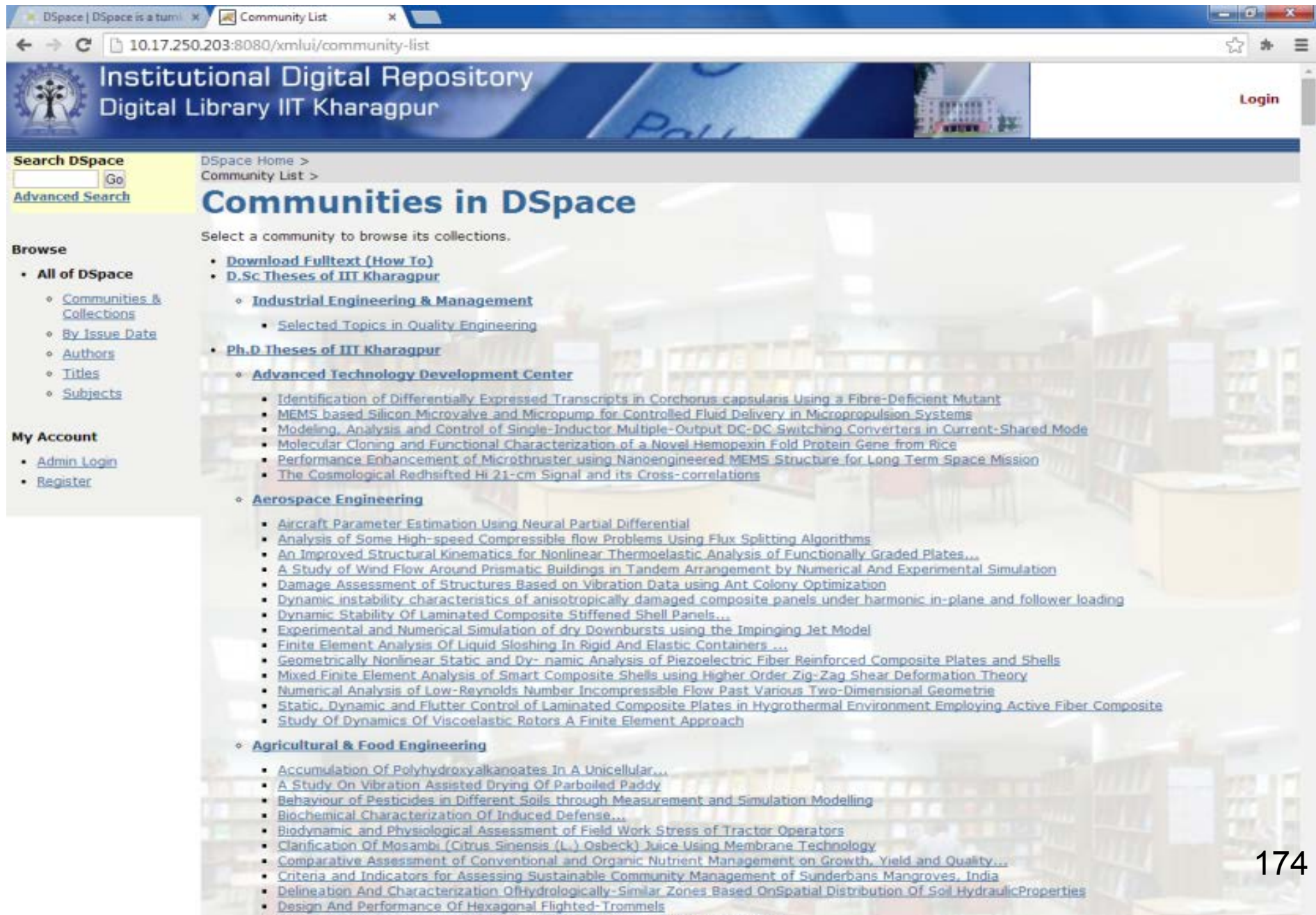

The screenshot displays the Institutional Digital Repository (IDR) website. The header includes the logo of IIT Kharagpur and the text "Institutional Digital Repository Digital Library IIT Kharagpur". A "Login" button is visible in the top right corner. The main content area is titled "Communities in DSpace" and lists various communities and their collections. The left sidebar contains navigation options like "Search DSpace", "Browse", and "My Account".

**Search DSpace**  
[Search Box] [Go] [Advanced Search]

**Browse**

- All of DSpace
  - Communities & Collections
  - By Issue Date
  - Authors
  - Titles
  - Subjects

**My Account**

- Admin Login
- Register

**Communities in DSpace**

Select a community to browse its collections.

- [Download Fulltext \(How To\)](#)
- [D.Sc Theses of IIT Kharagpur](#)
  - [Industrial Engineering & Management](#)
    - [Selected Topics in Quality Engineering](#)
  - [Ph.D Theses of IIT Kharagpur](#)
    - [Advanced Technology Development Center](#)
      - [Identification of Differentially Expressed Transcripts in Corchorus capsularis Using a Fibre-Deficient Mutant](#)
      - [MEMS based Silicon Microvalve and Micropump for Controlled Fluid Delivery in Micropropulsion Systems](#)
      - [Modeling, Analysis and Control of Single-Inductor Multiple-Output DC-DC Switching Converters in Current-Shared Mode](#)
      - [Molecular Cloning and Functional Characterization of a Novel Hemopexin Fold Protein Gene from Rice](#)
      - [Performance Enhancement of Microthruster using Nanofabricated MEMS Structure for Long Term Space Mission](#)
      - [The Cosmological Redshifted Hi 21-cm Signal and its Cross-correlations](#)
    - [Aerospace Engineering](#)
      - [Aircraft Parameter Estimation Using Neural Partial Differential](#)
      - [Analysis of Some High-speed Compressible flow Problems Using Flux Splitting Algorithms](#)
      - [An Improved Structural Kinematics for Nonlinear Thermoelastic Analysis of Functionally Graded Plates...](#)
      - [A Study of Wind Flow Around Prismatic Buildings in Tandem Arrangement by Numerical And Experimental Simulation](#)
      - [Damage Assessment of Structures Based on Vibration Data using Ant Colony Optimization](#)
      - [Dynamic instability characteristics of anisotropically damaged composite panels under harmonic in-plane and follower loading](#)
      - [Dynamic Stability Of Laminated Composite Stiffened Shell Panels...](#)
      - [Experimental and Numerical Simulation of dry Downbursts using the Impinging Jet Model](#)
      - [Finite Element Analysis Of Liquid Sloshing In Rigid And Elastic Containers ...](#)
      - [Geometrically Nonlinear Static and Dy- namic Analysis of Piezoelectric Fiber Reinforced Composite Plates and Shells](#)
      - [Mixed Finite Element Analysis of Smart Composite Shells using Higher Order Zig-Zag Shear Deformation Theory](#)
      - [Numerical Analysis of Low-Reynolds Number Incompressible Flow Past Various Two-Dimensional Geometrie](#)
      - [Static, Dynamic and Flutter Control of Laminated Composite Plates in Hygrothermal Environment Employing Active Fiber Composite](#)
      - [Study Of Dynamics Of Viscoelastic Rotors A Finite Element Approach](#)
    - [Agricultural & Food Engineering](#)
      - [Accumulation Of Polyhydroxyalkanoates In A Unicellular...](#)
      - [A Study On Vibration Assisted Drying Of Parboiled Paddy](#)
      - [Behaviour of Pesticides in Different Soils through Measurement and Simulation Modelling](#)
      - [Biochemical Characterization Of Induced Defense...](#)
      - [Biodynamic and Physiological Assessment of Field Work Stress of Tractor Operators](#)
      - [Clarification Of Mosambi \(Citrus Sinensis \(L.\) Osbeck\) Juice Using Membrane Technology](#)
      - [Comparative Assessment of Conventional and Organic Nutrient Management on Growth, Yield and Quality...](#)
      - [Criteria and Indicators for Assessing Sustainable Community Management of Sunderbans Mangroves, India](#)
      - [Delineation And Characterization Of Hydrologically-Similar Zones Based On Spatial Distribution Of Soil Hydraulic Properties](#)
      - [Design And Performance Of Hexagonal Flighted-Trombels](#)



**An Open Source Indian MOOCs Platform**

**Proposal for project under NMEICT**

**By**

**Prof. D. B. Phatak  
Department of Computer Science and Engineering,  
Indian Institute of Technology Bombay**

---

Submitted in May 2014

---

# Project Proposal Under NMEICT

## PART-I Information relating to Institute/Project

### 1. Name of Institute with complete address:

Indian Institute of Technology Bombay, Powai, Mumbai 400 076

### 2. Title, Duration, and total budget of the Project:

Title: An Open Source Indian MOOCs Platform

Duration: 3 Years

Budget: Rs 2964 Lakhs

### 3. Department/Broad Area:

Educational Technology, CSE/IT

### 4. Major areas of research in the Department:

Development of technologies relevant to education: Design and Delivery, Interplay between technology and pedagogy, Content development and Instructional design, Assessment and Evaluation of technologies, e-content and pedagogical techniques (See more at: <http://www.et.iitb.ac.in/>). Additionally, in association with several MHRD projects in the CSE and other departments, expertise has been developed to deliver training to 10,000 participants at a time, and in offering of MOOCs globally.

### 5. Names and Designations of Principal Researchers in the major areas and list of publication during last 5 years based on work done in the Department:

- (a) Prof. Deepak B Phatak, PI
- (b) Prof. Kannan Moudgalya, Chemical Engineering Department Co-PI
- (c) Prof. Vikram M Gadre, Head CDEEP, Convenor IDP Educational Technology Co-PI
- (d) Prof. Sridhar Iyer, CSE Department, and Associate faculty of IDP on ET Co-PI
- (e) Prof. Kameswari Chebrolu, CSE Department Co-PI

The resumes of the PI and Co-PIs, are enclosed in Annexure I.

### 6. Is it an Inter-disciplinary Project?

Yes.

### 7. Is it an Inter-Institutional Project?

Partly yes. IIT Bombay shall be the Institution with a responsibility for project execution. However, it is envisaged to establish of one or more consortia of Indian Universities/Institutions, as also to create an SPV (Special Purpose Vehicle) in the form of a Section 25 Company or equivalent. A very large number of students across the country, will

be learning MOOCs and Blended MOOCs courses, for which a close interaction with participating colleges and Universities will be essential.

*8. Is any Industry/User agency participating?*

No, but efforts will be made to invite participation from those IT industries which may be willing to contribute to this important Open Source Development of the platform and associated software development tools, at their own cost.

*9. Brief of completed and or on-going research projects supported by MHRD/AICTE in the Department during last 5 years.*

There are a large number of projects under NMEICT which have been successfully completed, or are being currently executed at IIT Bombay. The complete list is already available with the National Mission in MHRD.

## PART-II Information relating to department/institute

### *10. Principal Investigator*

- (a) Name: Prof. Deepak Phatak
- (b) Designation: Professor, Dept of CSE
- (c) Age: 66
- (d) Educational qualification: Ph.D
- (e) Experience: More than 40 years of teaching and research
- (f) Books and papers published: included in the resume of the PI

### *11. Is it a joint project with other Institution?*

Partly yes. IIT Bombay shall be the Institution with a responsibility for project execution. However, it will work in close collaboration with one or more consortia of Indian Universities/Institutions, as also with the Special Purpose Vehicle being created under this project. Interaction with Colleges and Universities, from where the students attend the offered MOOCs, will be essential.

### *12. Has an MOU been signed?*

IIT Bombay has signed an MOU with ISTE, for issuing formal training certificates to technical teachers participating in Training Workshops.

### *13. Present commitments of the Principal Investigator*

- (a) Teaching: two courses an year
- (b) Ph.Ds registered under him: currently none
- (c) Sponsored research: PI/Co-PI in projects from MHRD
- (d) Consultancy: One

### *14. Other members of the research group to work on the proposed project:*

Co-PIs at IIT Bombay will be:

- i. Prof. KannanMoudgalya, Chemical Engineering Department
- ii. Prof. VikramGadre, Head CDEEP, Convenor IDP Educational Technology
- iii. Prof. Sridhar Iyer, CSE Department, and Associate faculty of IDP on ET
- iv. Prof. KameswariChebrolu, CSE Department

## PART-III Main objectives/deliverables to be achieved in the project

### 15. Activities to be undertaken and completed in this project:

#### I. *Enhancing use of ICT for offering quality education using MOOCs*

- (a) to build and operationalize an Open Source Indian MOOCs platform, to cater to diverse needs of Indian educational system
- (b) to deploy the platform on one or more cloud environments in the country
- (c) to continuously support enhancements and further development to the platform to incorporate functionalities as required by emerging MOOC offerings.

#### II. *Teacher Training:*

- (a) Training on use of modern technology tools, associated emerging pedagogy, and the effective use of both in significantly enhancing the qualitative learning by students.
- (b) Specific training on flipped classroom, collaborative discussion forums, scalable LMS (Learning Management System), use of tablets and clicker application in class room, etc.
- (c) Training workshops for course design, development, and delivery using MOOCs platform.

#### III. *Establishing a self-sustaining system for continued operations of MOOCs*

- (a) An SPV (Special Purpose Vehicle) will be set up to handle all operations of such MOOCs offerings. It is likely to be in the form of a section 25 company for this purpose. Initial financial support is essential to kick-start such a venture. The project will provide technical and operational support for about 2 years of operations.
- (b) Establishment of one or more Consortia (e.g., centrally funded Institutes). While IIT Bombay will design and offer initial courses to students using MOOCs and Blended MOOCs, it is important for larger collaborative groups to be established in different domains, to enhance the scope and scale of MOOCs offerings. Such Consortia will act as perpetual feeders of design of high quality courses, and their offerings to students of different domains, on a continuing basis.

#### IV. *Student Training.*

- (a) Actual semester-long courses will be offered to the students of these colleges in specific subjects using blended MOOCs. Additionally, at least 6 such MOOC and Blended MOOC Courses will be offered using this platform, to students of multiple streams. These courses will also have repeat offering for subsequent years.

16. Budget Break-up

	<b>Year I</b>	<b>Year II</b>	<b>Year III</b>	<b>Total</b>
Equipment and Infrastructure	1050	325	Nil	1375
Salary	225	274	150	649
Course Design	40	40	40	120
Training Workshops	100	200	100	400
Consumables	30	50	30	110
Travel	50	60	40	150
Contingency	20	30	20	70
PI Honorarium (budgeted at 3%)	50	29	11	90
<b>Total</b>	<b>1565</b>	<b>1008</b>	<b>391</b>	<b>2964</b>

**Total Budget: Rs2964Lacs**

Breakup of these amounts in recurring and non-recurring part is given below. All amounts are in RsLacs

	<b>Year - I</b>	<b>Year – II</b>	<b>Year – III</b>	<b>Total</b>
Non-recurring	1050	325	0	1375
Recurring	515	683	391	1589
<b>Total</b>	<b>1565</b>	<b>1008</b>	<b>391</b>	<b>2964</b>



## Summary Sheet

1. *Name of the Institution:* IIT Bombay

2. *Title of the Project:* An Open Source Indian MOOCs Platform

3. *Name of the Department:*

Dept. of Computer Science and Engineering  
and the Centre for Distance Engineering Education Programme.

4. *Cost of the Project:* Rs. 2964 Lakhs.

5. *Amount released earlier if any:* Nil

6. *Utilization position in respect of grants released earlier for various projects (Details to be given project-wise):* Already available with NMEICT

7. *Reasons for unspent balance:* NA

8. *Name of the Principal Investigator responsible for implementation of the Project:*

Prof. Deepak B Phatak

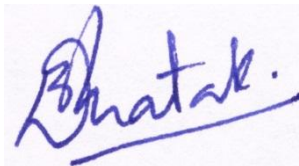

(SIGNATURE OF THE PRINCIPAL INVESTIGATOR)



## Certificate from IIT Bombay

Certified

1. that the Principal Investigator is not due to retirement during the currency of this project.
2. that the Principal Investigator is a regular employee of this Institution. However in case he/she proceeds sabbatical/resigns/proceeds VRS etc., the Institute will ensure to replace PI by a compatible academician to ensure that without any brake whatsoever, project will be completed within the stipulated period.
3. that it will be ensured that the implementation will be carried out on mission mode with no time or cost overrun and we are aware that ministry will neither provide any extension of time nor additional funding.
4. that no overheads will be charges by the Institution for this project and all facilitation including other essential/infrastructure support like air-conditioning etc. will be provided by the Institution.

Seal of the Institution



3/4/14

Signature of Head of the Institution

सह. संकायाध्यक्ष, शोध एवं विकास  
Associate Dean, Research and Development  
कृते निदेशक, आय आय टी मुंबई  
For Director, IIT Bombay

## Details of the project proposal

**Preamble:** It has been predicted that the next disruptive changes due to web, will occur in Education and Health care. Open source educational content of high quality, is now available in searchable digital formats. MOOCs(Massive Open Online Courses are gaining rapid popularity. Role of a teacher is getting redefined. Less of conventional lecturing, and more of advising, discussing, problem solving, is what a teacher in future will be expected to do.

IIT Bombay started distance education program in 2000, initially using VSAT and then switching to internet. We developed a unique method of blended use of technology. More than 5 years ago, we started conducting workshops for empowering teachers of engineering colleges. We first scaled up to engage 1,000 teachers at a time, in subject- specific training workshops of two-week duration. We identified a number of colleges as RCs(Remote Centres), where the participating teachers assemble in groups of 30 to 70. Interactive lectures are transmitted live from IIT Bombay using internet. Tutorials, laboratory sessions, and assignments are conducted at each RC, under the supervision of local Workshop Coordinators. The coordinators are faculty members at respective RCs, for whom a prior one-week orientation program is conducted at IIT Bombay. This is much like training our Teaching Assistants, but is more comprehensive. Encouraged by the positive results, we have scaled this program in partnership with IIT Kharagpur, to train up to 10,000 teachers at a time, who assemble at over 250 Remote Centers. In addition to training teachers in subjects which they teach, they are also trained in use of ICT to achieve a more effective teaching-learning process. This important initiative is funded by MHRD, under the National Mission on Education using ICT. *We believe that, globally, this is the first ever attempt of its kind, to simultaneously train engineering teachers on such a large scale.* We have already conducted several programs, and have trained over 80,000 teachers in this manner in several subjects. As mentioned, IIT Kharagpur is our partner Institution now, acting as an independent hub.

Need for training a large number of teachers in the professional higher education sector, has been paramount in India. We now have about 5000 engineering colleges, an increase from just about 100 colleges 30 years ago. Annual enrolment of students in these colleges is now over 12,50,000. The number of qualified and experienced teachers, is grossly inadequate. The scale gets compounded when we consider other domains of higher education and the vocational training requirements. As India moves to increase the GER(Gross Enrolment Ratio) in coming years, the need for quality teachers will considerably increase, and the supply-demand gap will widen further. It is thus necessary for available expert teachers to directly reach our millions of students. The challenge increases multi-fold, and conventional methods based on class room education cannot suffice at all.

It is in this larger context that we seek to use MOOC, albeit to be used later in a modified form, to permit blended education. Several consortia, mainly in the USA, have successfully built technology platforms, and have prepared pedagogical underpinning for MOOC offerings. There is considerable value in collaborating with an international consortium with this expertise and experience. We will have the ability to offer our courses internationally. The selected consortium will gain experience in teaching students from Indian academic environment. Of course, the main advantage of such collaboration to India, is that we can start using an already established technology platform with tested pedagogy, rather than spending years in developing one; and be joint partners in future development. A collaborative relationship will ensure future updates to the platform, to cater to our needs.

Udacity, Coursera, and edX are 3 main consortia in the US, offering MOOCs. Some new companies have become active in last year, such as Future Learn in UK. A committee deliberated at considerable length in choosing a suitable partner from amongst these. Our decision to partner with edX was influenced by several factors. One is that edX is a non-profit organization, initially funded by contributions of US\$60 Million, by the trustees of MIT and Harvard. There is nothing wrong with for-profit companies, but our comfort level is greater otherwise. Another is MIT's Open Course Ware (OCW) history. This is in consonance with our own desire to open-source as much knowledge content as possible. Last but not the least, is their decision to open source the edX platform itself, for future collaborative development.. Some of our regular courses will be available to lakhs of students across the nation, and to others globally. Quality education, imparted to our students on campus, can now be accessed by all learners.

Online courses and makers of e-learning artefacts often seem to imply a claim that an individual student can complete all studies in self-learning mode. There is no evidence yet to suggest so. On the contrary, a blended model has consistently been found better. Students study available digital material on their own. They then attend class room tutorials and discussion sessions, and practice solving problems in groups, under the supervision of a teacher. This flipped classroom model has been tried in IIT Bombay. It was found that the students do not always listen to pre-recorded lectures on their own as advised, and are often unprepared for classroom discussions. In any mass scale adoption of technology, issues of examinations, evaluation, and certification need to be addressed. The technology infrastructure must be adequate in terms of compute power and bandwidth. The transition to greater use of technology in education, may take several years. Technology Enabled Learning will continue to mature and evolve.

We work closely with edX for developing additional functionality by modifying the platform. We are integrating Moodle with this modified platform for use in our T10KT project. There has also been a parallel effort on developing a similar platform called Bodhitree, primarily for use in a flipped classroom scenario.

Our future vision is to explore, examine, and solve all such pedagogical and technical issues, and establish the best possible model of blended learning, for Indian education system. IIT Bombay hopes to provide the leading edge for a smooth transformation. Our Educational Technology program reflects this desire. Research and development being done at IIT Bombay in this context, through our Interdisciplinary program on Educational Technology include: creation of courses under NPTEL, Spoken Tutorials, Educational animations, Design and development of educational robots, Development of educational content and applications on Low cost Aakash tablet computer, etc. Our graduate program in Educational Technology is actively involved in research and education in the area of technologies to promote the learning-teaching process. The thrust areas of research include: Development of technologies relevant to education (design and delivery), Interplay between technology and pedagogy, Content development and instructional design, etc. The experience, expertise and vision, have prompted us to make a proposal to build an Indian platform, which can offer various kind of courses at all levels to Indian students, catering to the specific evolving needs.

**Proposal** :It is proposed to build and operationalize an Open Source Indian MOOCs platform, to cater to various needs of Indian educational system, such that MOOCs can be offered easily in different domains. The proposal is to suitably modify and enhance the Open Source edX platform, incorporate components of Bodhitree where relevant, and install it on a cloud. This will enable various courses in different domains to be offered from within India. It is proposed to establish one or more consortia of Indian educational Institutes, e.g. a consortium of centrally funded Institutions.

It has been suggested by MHRD, as articulated by secretary (HE) himself in meetings of PAB, that an SPV (Special Purpose Vehicle) be set up to handle all operations of such offerings. IIT Bombay has already resolved to set up a section 25 company for this purpose. Currently, the detailed structure for such a company is being worked out. The main problem is that such a company can start earning revenues only after about 2 years of operations. Initial financial support is essential to kick-start such a venture e.g. edX, is a similar not-for-profit company set up by MIT and Harvard, with an initial contribution of US\$ 60 million. It is proposed to set up such a company as a part of this project.

PI and all the four Co-PIs have extensive experience and expertise to ensure achievement of these objectives, as is evident from their CVs, enclosed in annexure I

## **Quantified Deliverables and Timelines**

### ***1. Platform Development and deployment***

(i) August 2014: Delivery of early version of the platform, termed version 0, to be deployed on T10KT servers, to be made available to a limited number of Institutions to run their courses.

The necessary cloud and Hadoop infrastructure will be set up in the Institute for development and testing, as also for pilot delivery of courses. As and when the NMEICT server cloud is operational, the platform will also be deployed on that cloud. Work has already been initiated on the development of this version, because this platform was planned to be used for Teacher Training (T10KT project), and for delivering the first two pilot courses in Blended MOOC model.

(ii) December 2014: Delivery of version 1 of the platform to be deployed on the mini-cloud system in IIT Bombay, and also on the NMEICT cloud in Delhi.

The approach in achieving this is to first conduct a detailed design review of the architecture, and to define the detailed functional requirements by considering the best features of openedX and of BodhiTree; and by adding functions whose need is discovered in the pilot use of the Version 0. Detailed test criteria, and performance metric will also be defined and benchmark tests will be developed using the open source tool JMeter. Since the proposed project team and the server resources will be in place in about 3 months, we will be in a position to deliver.

(iii) March 2015: Delivery of a tailored version which can be used on smaller servers within individual Institutions/Colleges. Such a version is envisaged even now for T10KT, and pilot

blended MOOC offering. The detailed technical description of the development being done now through summer interns of T10KT project, is included in Annexure II. The technical and usage details of the BodhiTree are included in Annexure III.

(iv) March 2016: Version 2 of the platform with enhanced state of the art features will incorporate requirements which have emerged during the first 1 year of operations, and will cater to special needs of different domains.

## ***2. Formation of SPV and one or more Consortia***

(i) December 2014: Formation of a not-for-profit under section 25 company (now perhaps under Section 8, as per the company law amended in late 2013).

IIT Bombay has experience in setting up such companies. Examples of successfully running entities created at IIT Bombay are SINE (Society for Innovation and Entrepreneurship), which is established as a charitable trust, and the IIT-Monash Academy, established as a section 25 company. SINE is recognized today as the best incubator in the country, and the PI of this proposed project was responsible for its conceptualization and pilot creation.

(ii) March 2015: - Establishment of one or more Consortia (e.g., centrally funded Institutes). Guidelines for Consortia and section 25 company, to provide services for running MOOCs.

(iii) March 2016: - Company to start working independent of the Mission Support. This is the key to the entire proposal. The handholding for about two years is required, but then onwards the company is expected to start generating its own revenue to sustain its operations further. During this time, the charging policy and the revenue model is expected to have evolved properly. In the third year, the project will hand over the complete and detailed knowhow of the open source platform to the company.

## ***3. MOOCs Training and courses***

(i) December 2014 to July 2015: Training of teachers on design of MOOCs on the platform.

Six or more short familiarization workshops will be conducted by the project for teachers on use of the platform. Two of these will be conducted by IIT Bombay for Teachers/staff of various Engineering and Science colleges. Four or more will be conducted by experts from other domains using the platform, with financial and operational support from the project.

(ii) Courses for students

At least 4 basic courses in engineering will be designed and developed at IIT Bombay, to run on this platform. Two of these will be offered in blended MOOCs as pilot during July-December 2014, with limited enrollment of 10,000 to 30,000 students per course. Two more will be designed in the next year. All four will be offered in subsequent academic

semesters/years for students of all colleges willing to accept blended MOOCs. Potential enrollment is estimated to be between 50,000 to 1,00,000 students per course.

Similar courses are expected to be offered by other consortium members.

### **Budget Requirements**

The main funding requirements will be for the software development, and the minimal hardware essential for development and for pilot delivery.

Some details are given below, reflecting the salary calculations

Senior Staff/Advisors (Salary range 60,000 to 90,000)

Avg 75,000 \* 10 = 7.5 \* 12 = 90.0

Senior Software Engineers (Salary range 40,000 to 60,000)

Avg 50,000 \* 6 = 3.0 \* 12 = 36.0

Programmers (Salary range 25,000 to 40,000)

Avg 30,000 \* 15 = 4.5 \* 12 = 52.0

Admin staff (Salary range 15,000 to 40,000)

Avg 25,000 \* 10 = 2.5 \* 12 = 30.0

Documentation and Dissemination staff (Salary range 25,000 to 40,000)

Avg 30,000 \* 5 = 1.5 \* 12 = 18.0

Workshop staff (Salary range 30,000 to 50,000)

Avg 40,000 \* 10 = 4.0 \* 12 = 48.0

These are for the team which will be working in year 2 of the project. In the first year, the salary budget required will be a bit less (for about 9 to 11 months for different staff. In the third year, when most of the operations are expected to be run by the SPV, the budget requirement is substantially less.

Equipment and Infrastructure budget is estimated at Rs 1050 Lakhs in first year. This will include a mini-cloud set up, for the test and development system, and for the pilot delivery of the courses. Additional procurement of smaller systems and resource augmentation by adding more servers and storage to the cloud farm will be carried out in year 2, for which a provision of Rs 325 Lakhs has been made.

Requirement for the other budget heads, such as travel, contingency, etc., have been made based on our experience of running such large projects in the recent past.

The total budget provision is presented in the table on the next page.

**Budget Requirements (in Rs. Lakhs):**

	<b>Year I</b>	<b>Year II</b>	<b>Year III</b>	<b>Total</b>
Equipment and Infrastructure	1050	325	Nil	1375
Salary	225	274	150	649
Course Design	40	40	40	120
Training Workshops	100	200	100	400
Consumables	30	50	30	110
Travel	50	60	40	150
Contingency	20	30	20	70
PI Honorarium(budgeted at 3%)	50	29	11	90
<b>Total</b>	<b>1565</b>	<b>1008</b>	<b>391</b>	<b>2964</b>

In terms of conventional costing per student benefitting from the project, even if we assume a conservative number of only 6,00,000 students using the MOOCs in all the 3 years, the cost per student works out to just about Rs 500. The actual number of students is likely to exceed significantly



NMEICT

*Thank  
You*

Mission Secretariat